

# Catch the Bug

Unit 1



NAME \_\_\_\_\_

Adapted from the *4-H Entomology Member's Guide* prepared by the National 4-H Entomology Program Development Committee.

Adapted and revised by Tracy L. Newton, graduate student, Department of Agricultural and Extension Education. Reviewed by Richard Stinson, professor emeritus, Department of Agricultural and Extension Education, and Maryann Frazier, senior extension associate, Department of Entomology. Assistance was provided by Dennis Scanlon, associate professor, Department of Agricultural and Extension Education; and by Charles Pitts, professor; Robert Snetsinger, professor; Greg Hoover, senior extension associate; Steve Jacobs, senior extension associate; and Sven-Erik Spichiger, student, Department of Entomology.

Penn State College of Agricultural Sciences research, extension, and resident education programs are funded in part by Pennsylvania counties, the Commonwealth of Pennsylvania, and the U.S. Department of Agriculture.

Where trade names appear, no discrimination is intended, and no endorsement by Penn State Cooperative Extension is implied.

Issued in furtherance of Cooperative Extension Work, Acts of Congress May 8 and June 30, 1914, in cooperation with the U.S. Department of Agriculture and the Pennsylvania Legislature. T. R. Alter, Director of Cooperative Extension, The Pennsylvania State University.

This publication is available in alternative media on request.

The Pennsylvania State University is committed to the policy that all persons shall have equal access to programs, facilities, admission, and employment without regard to personal characteristics not related to ability, performance, or qualifications as determined by University policy or by state or federal authorities. The Pennsylvania State University does not discriminate against any person because of age, ancestry, color, disability or handicap, national origin, race, religious creed, sex, sexual orientation, or veteran status. Direct all inquiries regarding the nondiscrimination policy to the Affirmative Action Director, The Pennsylvania State University, 201 Willard Building, University Park, PA 16802-2801; Tel. (814) 865-4700/V, (814) 863-1150/TTY.

© The Pennsylvania State University 1996  
3M398PS

## CONTENTS

<b>1</b>	<b>INTRODUCTION • WELCOME TO ENTOMOLOGY!</b>
<b>2</b>	<b>MEETING 1 • LET'S GET BUGGY</b>
2	Where to look for insects
3	Record keeping
4	How to make a net
5	Putting the net together
<b>6</b>	<b>MEETING 2 • BUG BASICS</b>
6	How to identify insects
8	What are insects made of?
9	Testing your memory
10	How to make an insect killing jar
11	How to prepare the killing jar
12	How to collect insects
<b>14</b>	<b>MEETING 3 • UP, UP AND AWAY!</b>
14	Insect characteristics
15	Metamorphosis
16	Wings, mouthparts, and metamorphosis review
17	Relaxing dry specimens
18	Pinning insects
19	Making a pinning block
<b>20</b>	<b>MEETING 4 • MAY I TAKE YOUR ORDER?</b>
20	Learning the major insect orders
23	Matching insects to their order
24	Making a spreading board
25	How to spread butterflies and moths
<b>26</b>	<b>MEETING 5 • FUN IN THE FIELD!</b>
26	Field Trip
<b>28</b>	<b>MEETING 6 • SMALL FRIES</b>
28	Activity: Less common insects
30	Using a key
33	Card pointing and labeling small insects
<b>34</b>	<b>MEETING 7 • WHAT'S IN A NAME?</b>
34	The scientific name
35	Find the impostors
37	How to make a collection box
38	How to make a display case
<b>39</b>	<b>MEETING 8 • SNAPPY TRAPS</b>
39	Presentations and collections on display
<b>40</b>	<b>JOIN IN!</b>
<b>41</b>	<b>INSECT RECORDS</b>
<b>48</b>	<b>GLOSSARY</b>

PENNSTATE



College of Agricultural Sciences • Cooperative Extension

# WELCOME TO ENTOMOLOGY!

---

Insects are the coolest creatures on our planet. They have existed for about 300 million years, even before the dinosaurs! There are more different kinds of insects in the world than any other type of animal. Did you know there are more than 750,000 types of insects? Some insects are so small you need a microscope to see them, and some are bigger than your fist or longer than your arm! They can be found almost anywhere. They live in the air, on and under water, on plants, under rocks, in soil, just about everywhere we look—even in our houses! Insects eat everything from human blood and plant juices to horse manure. Some insect pests actually eat 100 times their weight each day! That is like a human eating about 10,000 pounds of food a day!

Many people don't realize how much insects affect our lives. They can be both beneficial and harmful. Insects eat about one-third of the food we grow, making life difficult for farmers. Some insects cause illness and even death by transmitting harmful diseases to humans and animals through their bites. Did you know that about half of the deaths in the world are caused by insect-related diseases? Some insects are just plain irritating as they buzz about our heads, and others can cause painful stings. However, only a small number of insect species are harmful. Many are beneficial and even essential to our lives. Honey bees pollinate our fruit and nut trees and also produce wax and honey. Silkworm caterpillars produce silk used in cloth. Insects also provide food for animals like fish, frogs, and birds, and they help break down dead animals, plants, and waste products of animals. Certain insects, called *beneficials*, eat the insects that cause major

damage to our food crops. It is easy to see that insects are very helpful to humans.

Entomology is the study of insects, and entomologists are the people who study insects for a career. Some entomologists work in insect museums, while others perform research on insects or the diseases they carry. Some entomologists are beekeepers, while others are exterminators. Entomologists may study the insects that are found on dead bodies to help solve murder cases. These entomologists are called forensic entomologists. Entomologists also work at airports or country borders, where they make sure unwanted insects don't enter our country and cause damage. These entomologists are called quarantine officers. Some entomologists work as chemists and try to develop new pesticides to control insect pests on our crops, while others rear beneficial insects for use in pest control.

Entomology is a science that is challenging and very rewarding. It involves biology, ecology, economics, horticulture, plant pathology, microbiology, genetics, physiology, and chemistry. Since insects are found almost everywhere and eat almost anything, there are always new and interesting facts to learn about insects. New insects are discovered everyday in all parts of the world, and the need for skilled entomologists is growing. If you have any questions about the study of entomology or careers in entomology, contact the Penn State Department of Entomology at (814) 865-1895.



# WHERE TO LOOK FOR INSECTS

*Draw your own pictures or cut out pictures from old magazines and paste them in for each of the following:*

In the air on warm days  
from spring to fall



On (or in) fresh  
or decaying fruit

In swimming pools

On plants or grasses,  
both day and night

In the soil

In garbage or on decaying  
matter

Around street lights  
or porch lights

Under rocks and on trees,  
shrubs, or flowers

On animals or pets

In woodpiles,  
especially in spring  
and early summer

In houses

Along the edges of rivers,  
streams, lakes, or ponds  
and in the water



# HOW TO MAKE A NET

To construct a net bag, lay a 20-by-30-inch piece of net material (muslin or netting) on top of another piece of the same size (Fig. A).

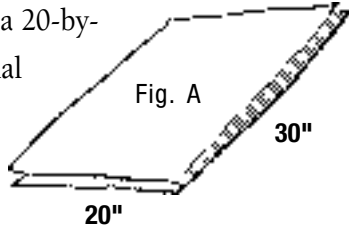

Fold them in half crosswise so that the folded material is 10 by 30 inches (Fig. B). Starting from the bottom folded corner, cut the material diagonally up and across to a point 10 inches below the top unfolded corner (Fig. C).

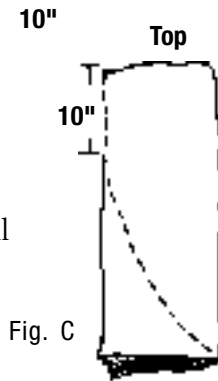
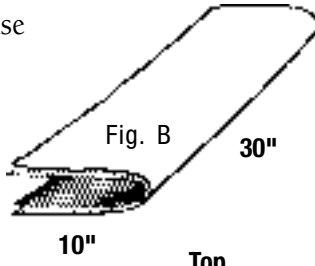

After cutting, the net bag will be in two roughly triangular-shaped pieces (Fig. D).

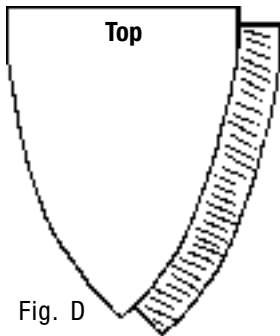

To stitch the net bag together, start at one of the top corners and stitch down the side, 3/4 of an inch in from the cut edge.

Continue stitching around the bottom point and back up the other side, stopping 10 inches below the top edge (Fig. E). Turn the net back right-side-out. Stitch along the sides again (Fig. E) 3/4 of an inch in from the edge, so that the

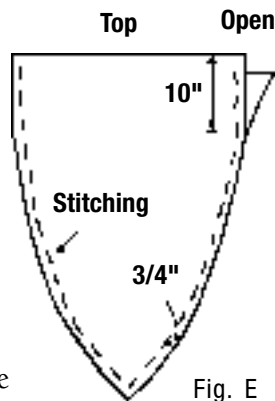

## Materials needed:

1. two 20-by-30-inch pieces of net material
2. scissors
3. sewing machine or needle
4. ruler or measuring stick
5. thread to stitch net
6. Optional: 5-by-40-inch strip of muslin

cut edges are enclosed by stitching (Fig. F).

To make a pocket to slip the wire hoop into, fold the top edge down 5 inches (Fig. G).

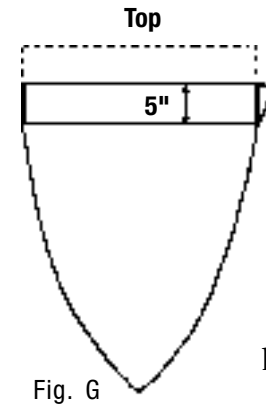
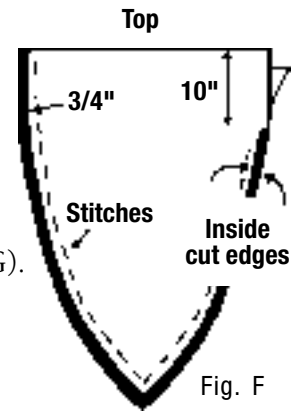

Then turn the folded edge down 2 inches and stitch the hem (Fig. H).

If you would like to reinforce the hem of aerial nets made of netting,

you can make only one fold (5 inches) and cover the fold with a 5-by-40-inch strip of muslin. Turn the folded edge down 2 inches and stitch. The muslin will protect the netting around the wire hoop.

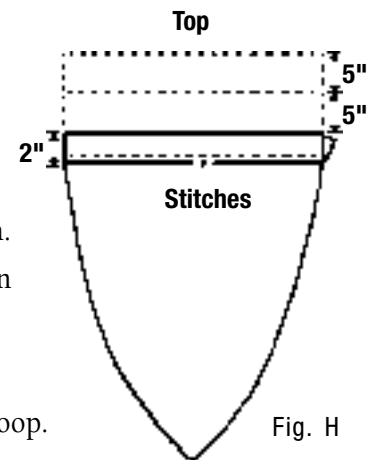

## PUTTING THE NET TOGETHER

### How to assemble:

1. Bend heavy wire into a circle (about 12 inches) to form a hoop. Bend arms 2 1/2 inches and 3 1/2 inches for fitting in the net handle.

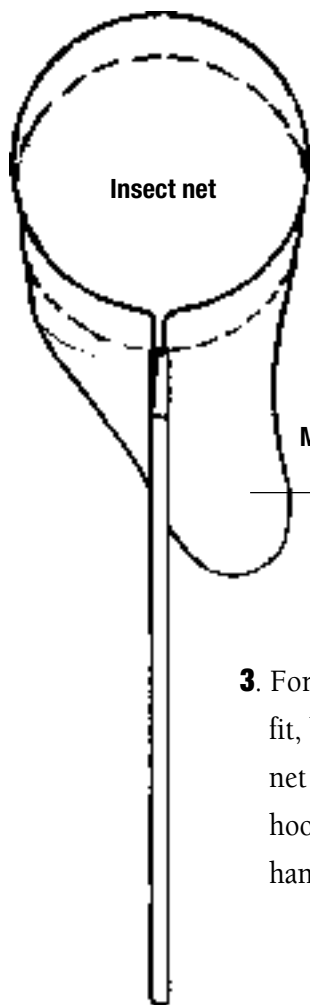
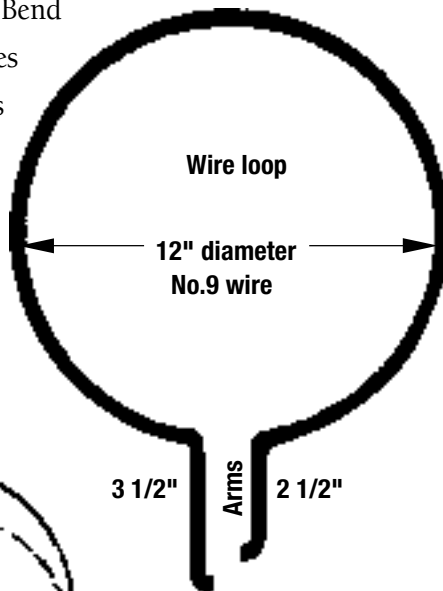

2. Using the net bag you just made, thread the wire hoop through the hem of the bag

Muslin or netting

3. For the most secure fit, bore holes in the net handle for arm hooks and groove the handle as shown.

Groove



### Materials needed:

1. wood handle, 3 feet long (broom handle or dowel)
2. about 4 feet of heavy wire (number 9) for the hoop or a wire hanger
3. soft wire, heavy string, duct tape, or metal sleeve for net handle to hold hoop wire
4. net bag from previous page

4. Insert the wire arms into the handle. Slip the metal sleeve over the net handle to hold the wire arms in place.



Wire or string

Soft wire or strong string also can be used to hold wire hoop in place. For a less secure fit, simply lay wire arms against the handle's end and duct tape them to the handle.

Metal sleeve



*NOTE: This exercise may require adult assistance. For easy and cheap construction, substitute a pillow case for netting material. Also, nets can be ordered through biological supply companies or from certain craft stores.*

# HOW TO IDENTIFY INSECTS

This unit is important because after you catch the insects for your collection, you will have to identify and label them using their scientific names.

## All the creatures of the world are divided into five groups called kingdoms:

ANIMALS



PLANTS



FUNGI



BACTERIA

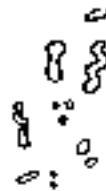

PROTOZOA



*Believe it or not, every living thing in the world fits into a category with a name. Otherwise, how would people be able to study all these creatures? There are between 750,000 and 1,000,000 insects already named in the world. How would you like to try to study them without a classification system?*

### **Insects are in the animal kingdom.**

The animal kingdom is then divided into vertebrates (animals with a backbone) and invertebrates (animals without a backbone).

### **Insects are invertebrates.**

Invertebrates are divided into phyla (fi´ luh).

### **Insects are in the phylum Arthropoda,**

meaning “jointed legs.” There are several different groups or classes of arthropods.

### **Insects are in the class Hexapoda,** meaning “six legs.”

Arthropod classes include (see opposite page):



**Arachnida** (A rack nid´ a)—spiders, ticks, mites, scorpions

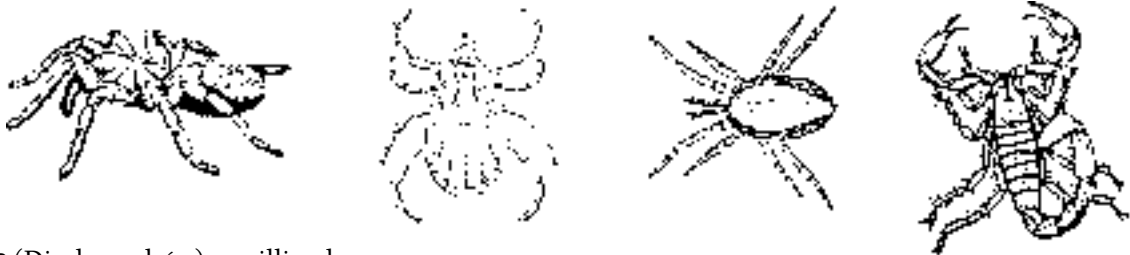

**Diplopoda** (Dip lo pode´ a)—millipedes



**Chilopoda** (Chill a pode´ a)—centipedes

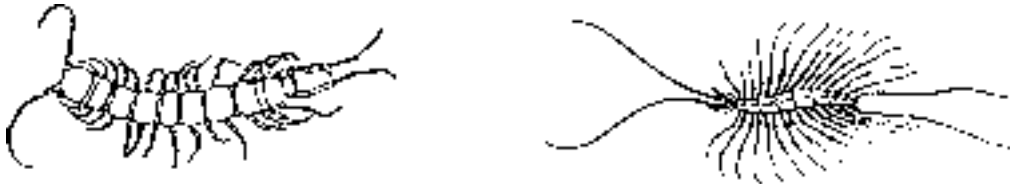

**Crustacea** (Crust a´ she a)—crabs, shrimp, crayfish, and their relatives

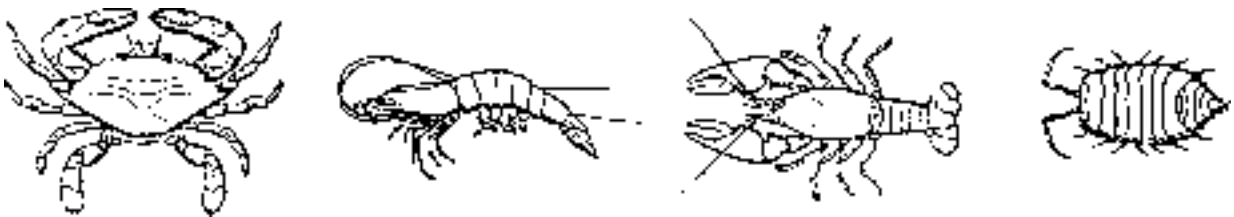

**Hexapoda** (Hex a poda´ a)—insects

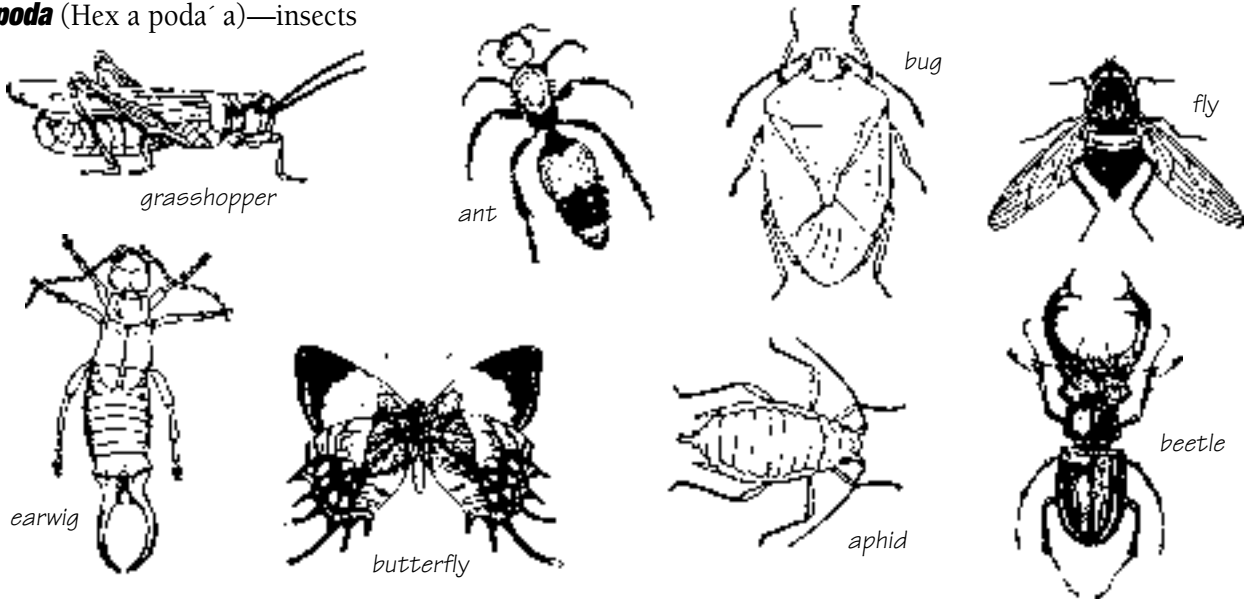

# WHAT ARE INSECTS MADE OF?

All insects have the following characteristics in common.

1. A skeleton (hard covering) on the outside of the body called an **exoskeleton**, which protects the insect. The exoskeleton of an insect is made up of **chitin**.
2. Three body regions. The head holds the eyes, mouthparts, and antennae. The **thorax** is the middle part where the legs and wings are attached. The **abdomen** is the part behind the thorax and contains the organs of digestion and reproduction.
3. Six legs (three pairs). Each pair is connected to a segment of the thorax.
4. Two **antennae**. The antennae are on the front of the head. They serve as organs of touch and sometimes taste, smell, and hearing. They are often called “feelers.”

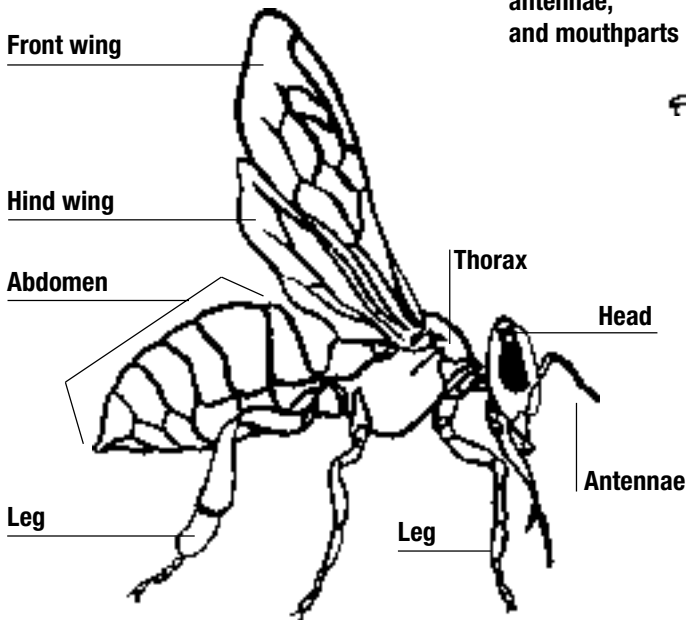
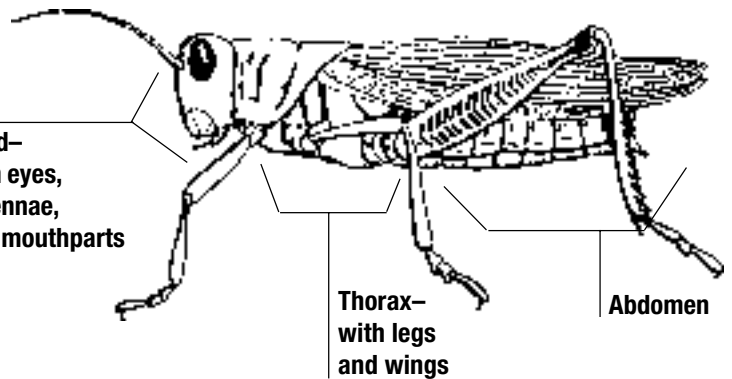
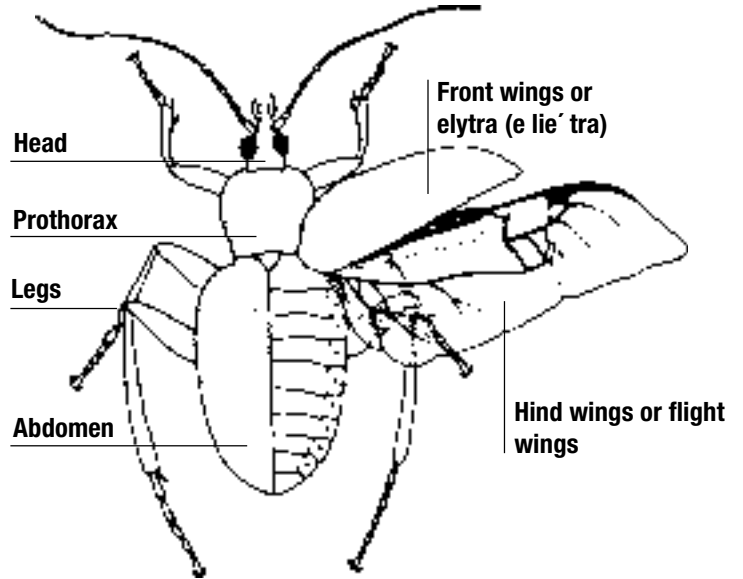

# TESTING YOUR MEMORY

Try to answer the following questions without looking back at the material you just read.

**1.** Can you remember the five kingdoms of creatures?

---

---

---

---

---

**2.** What kingdom are the insects in?

---

**3.** What are animals with backbones called?

---

**4.** What are animals without backbones called?

---

**5.** Insects are (circle one):

vertebrates                      invertebrates

**6.** List the creatures in each class of arthropods.

**Arachnida**

---

---

**Chilopoda**

---

---

**Diplopoda**

---

---

**Crustacea**

---

---

**Hexapoda**

---

---

**7.** Can you name three of the four characteristics that all insects have in common?

---

---

---

**8.** What is an **exoskeleton**?

---

**9.** What is **chitin**?

---

**10.** What are **antennae**?

---

---

**11.** What is a **thorax**?

---

---

**12.** Can you label the parts of this insect? Use the terms **head, thorax, abdomen, antennae, front wing, hind wing, leg.**

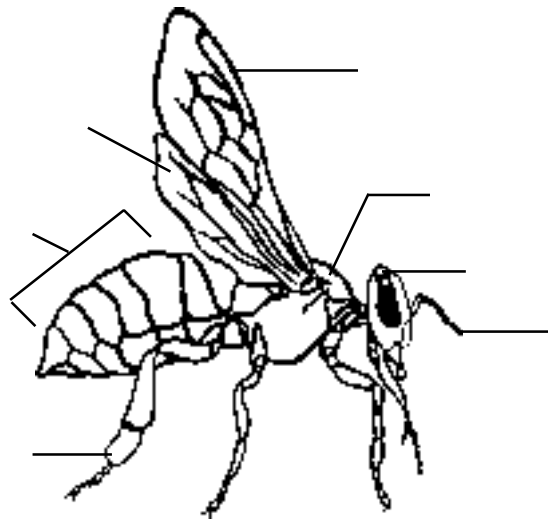

## HOW TO MAKE AN INSECT KILLING JAR

The size of the killing jar depends on the size and kind of insect collected. For butterflies and moths, a wide-mouth jar with a screw cap is satisfactory. Never mix other insects in the same killing jar with your butterflies and moths. They can be easily damaged by beetles, wasps, and other hardier insects. A smaller wide mouth jar can be used for collecting other insects. Make several jars at a time so that you will always have extras if any get broken.

### KILLING JAR

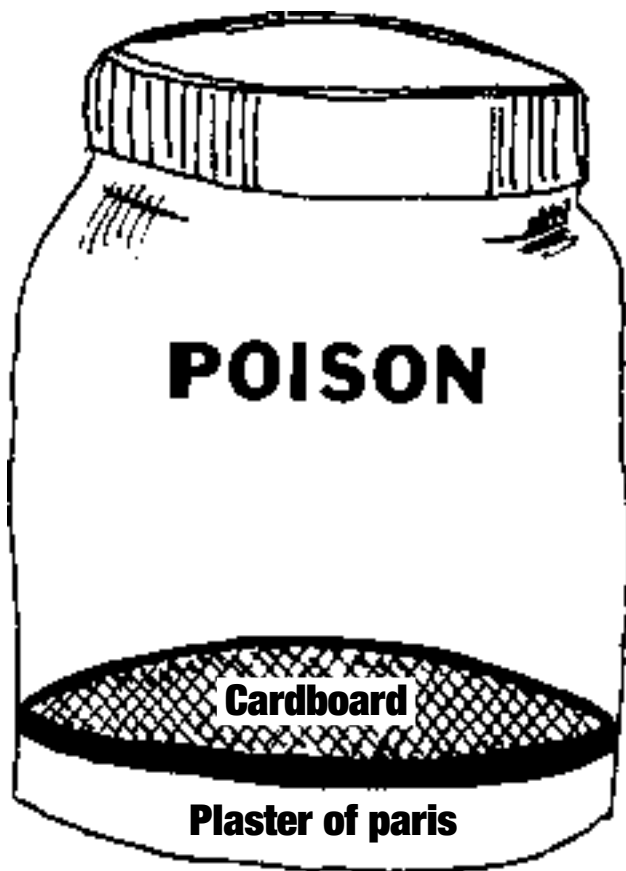

### Materials you will need:

- several jars of different sizes with tight lids
- plaster of paris
- water
- ethyl acetate or fingernail polish remover
- mixing cups or bowls
- stirring utensils
- cardboard
- scissors

*TIP: As a safety measure, you may want to tape the bottom and lower sides of the jar with masking tape. This will prevent some breakage in case the jar falls. Also, to prevent mold, you may want to put moth balls or naphthalene flakes into the jar. These can be put into a pouch and taped to the bottom of the lid.*

**CAUTION:** As with handling any chemical, be careful not to inhale ethyl acetate fumes.

## HOW TO PREPARE THE KILLING JAR

1. Cut out a piece of cardboard that will fit in the bottom of the jar and then remove it. Do this for each jar you have.
2. Mix several heaping teaspoons of plaster of paris with a few tablespoons of water in a mixing cup. Continue until it makes a paste about as thick as a frosted malt drink.
3. Stir the mixture until smooth.
4. Pour or spoon 3/4 to 1 inch of the mixture into the killing jars so the plaster of paris makes a smooth surface.

*With the cap off the jars, let the plaster of paris set for several days until it is thoroughly dry. When dry, the plaster of paris becomes paper white. At this time, take the jar outdoors to charge it with your killing agent.*

6. With the wind at your back to avoid inhaling the fumes, pour as much killing agent (ethyl acetate) into the killing jar as will be absorbed by the plaster of paris. Then pour out any excess liquid.
7. Put the cardboard on top of the plaster of paris and cap the jar immediately.

*Always keep the jar tightly covered except when placing insects in the jar or taking them out because the killing agent evaporates very rapidly. When it seems that the insects are taking an abnormally long time to die in the killing jar, it is time to recharge the jar with your killing agent. To recharge your jar, remove the cardboard and repeat steps 6 and 7.*

### Alternative killing jar

Take an empty film container and poke holes in the sides. Glue the bottom of the film canister to the lid of the jar. Insert a piece of charged cotton into the film container and put on the lid. This way, the insects don't risk damage or dusting caused by cardboard or plaster of paris. These conditions are also less suitable for mold growth.

To recharge the jar, take the lid off the film container and add more killing agent to the cotton ball or change cotton balls. Recap the lid of the film container.

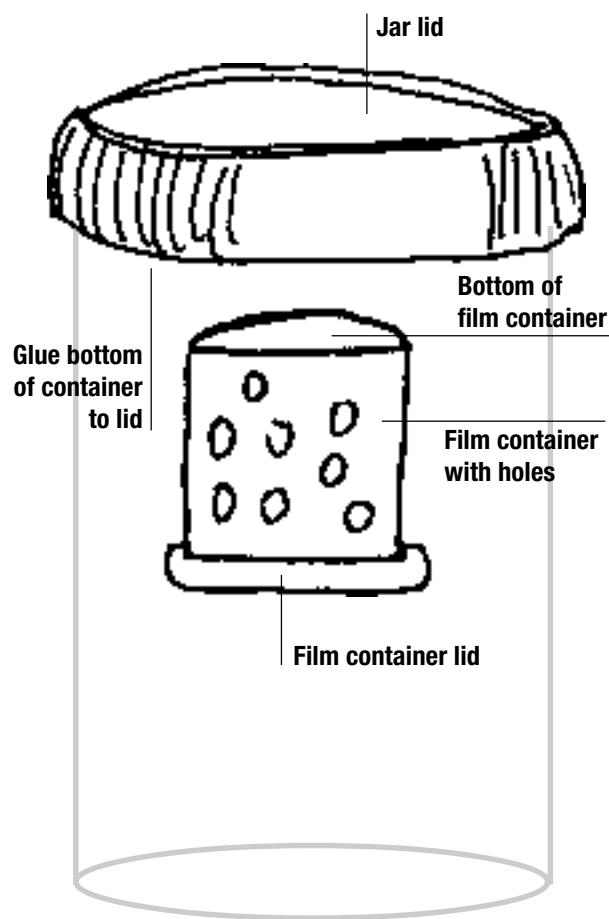

## HOW TO COLLECT INSECTS

There are several ways you can collect insects. Some insects can be caught by a net, some in your hands, and some in a jar. It is important to know how to catch insects safely without damaging them or hurting yourself. For example, you wouldn't want to catch a bee in your hand, would you?

Flying insects are easiest to catch with a net. You can catch flying insects in the air by scooping them into the net or you can sweep the net across plants and collect insects when they are resting or feeding on a flower. When using a net, you want to thrust the net swiftly so the insect ends up at the bottom of the bag. Then turn the net over so the opening is facing the ground and the rest of the net is draped over the side, like this:

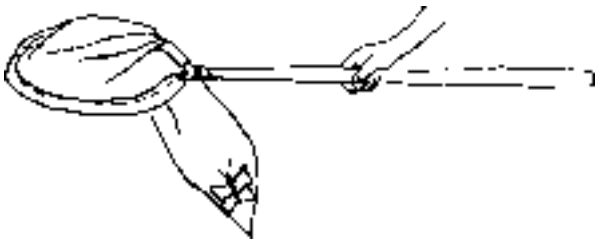

### Butterflies and moths

You must be very careful when collecting butterflies and moths with a net. Once you trap them, they tend to damage their wings. Grab the net with one hand between the opening and the butterfly.

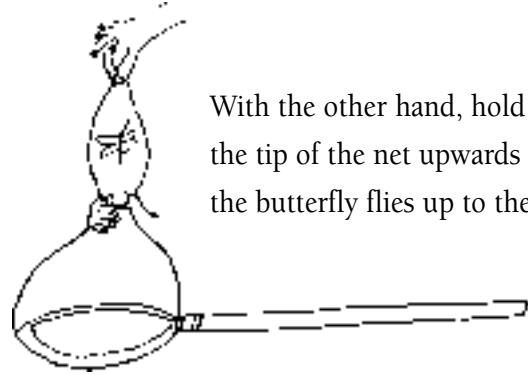
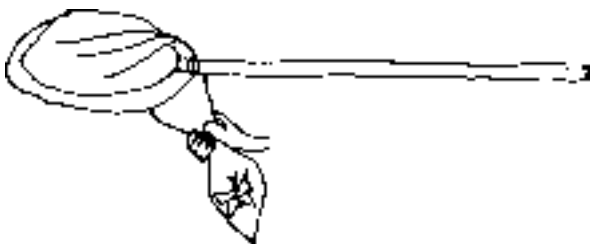

With the other hand, hold the tip of the net upwards so that the butterfly flies up to the end.

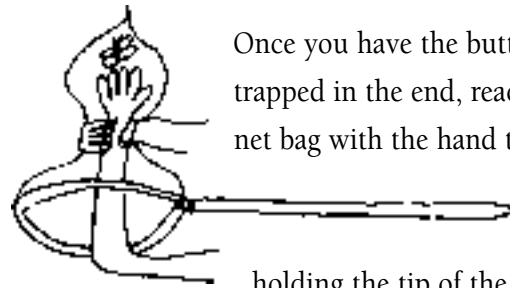

Once you have the butterfly trapped in the end, reach into the net bag with the hand that was

holding the tip of the net. Slide your fist down around your arm securing the net to keep the butterfly from escaping.

Grab the butterfly or moth between your thumb and pointer finger and squeeze the neck area. Don't squeeze so hard that the guts come out! This will stun the insect and make it easy for you to put it into the killing jar.

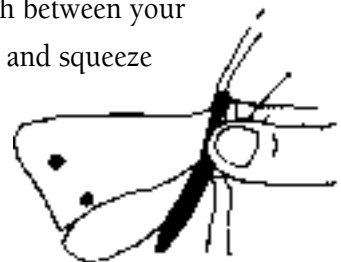

If you find your butterflies keep escaping and you need practice, grab the butterfly's thorax while it is still under the net. Hold the insect in your fingers for a few minutes until it becomes weak. Then reach in and grab the butterfly and transfer it into the killing jar. This may damage the wings, but it will give the practice you need.

## Other nonstinging insects

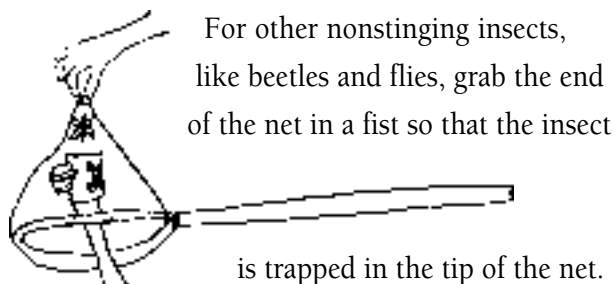

For other nonstinging insects, like beetles and flies, grab the end of the net in a fist so that the insect

is trapped in the tip of the net.

Grab your killing jar. Take off the lid.

Put it inside the net under your fist. Release your fist and trap the insect inside the jar. Slide the jar down the net until you reach the opening and put the lid on.

## Stinging insects

If you have a stinging insect in the net or don't want to put your hand into the net while the insect is moving, take the part of the net that the insect is trapped in and put it inside the jar for about a minute, or until the insect is motionless. Make sure it is completely stunned before you handle it! Then you can take the insect out of the net, put it back into the killing jar, and use your net again.

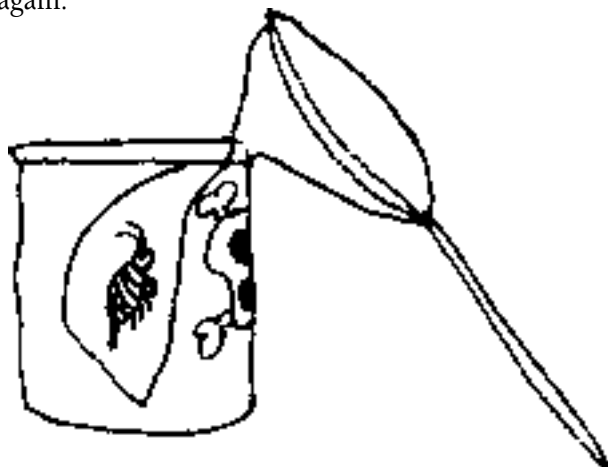

## Other ways to collect insects

You can also catch harmless insects in your hands and transfer them into the killing jar. Or collect them directly in a jar by holding the lid in one hand and the jar in the other and clapping the two together with the insect trapped inside. Be careful not to close a wing or leg in the jar lid!



## How long in the killing jar?

The bigger the insect, the longer time it will need to be in the killing jar. Once you no longer see any movement of the insect, leave it in for a few more minutes. The killing agent in the jar dries out really quickly, so don't keep the lid off too long. Also, don't stand directly over the jar or stand facing into the wind so the fumes blow in your face.

*Avoid inhaling these fumes.*

# INSECT CHARACTERISTICS

The lesson and exercise in this unit will help you learn about characteristics of insects that help us group them into orders.

Insects need to be divided into groups in some way. You wouldn't think that butterflies and beetles are in the same group, would you? Of course not. The group Hexapoda is divided into several different **orders** of insects. They are divided according to many characteristics, including their **wings, mouthparts, and life cycle**.

## Wings

Insects may have no wings, one pair of wings, or two pairs. The wings may be covered in **scales** (powdery parts of the wings of butterflies and moths).



Some insects, such as wasps, have clear wings with veins showing through. These are called **membranous** wings.

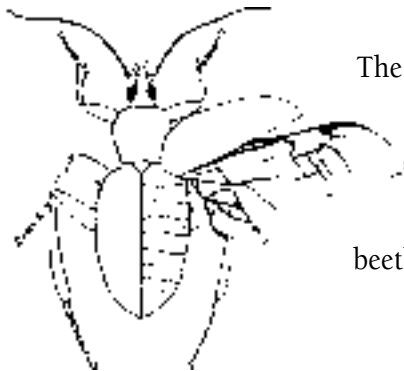
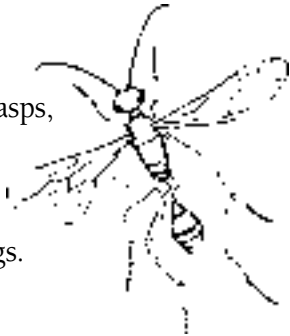

The outer wings may be hard and **shell-like**, such as a beetle's wings.

## Mouthparts

The mouthparts of an insect vary also. They may be either **chewing, piercing-sucking, siphoning** (tube-like mouthparts that take up food source like a soda straw), or **sponging**, or they may not have any mouthparts at all!

Mayflies spend all but one day of their lives in the water. They emerge as adults, fly out of the water, mate, lay eggs, and die all in the same day. Therefore, they have no mouthparts as adults because they do not live long enough to eat.



**chewing**



**piercing-sucking**



**siphoning**



**sponging**



**none**



# METAMORPHOSIS

Each insect also grows up and changes shape, a process called **metamorphosis**. There are three different types of metamorphosis.

## SIMPLE METAMORPHOSIS

(*silverfish, springtails, lice*)

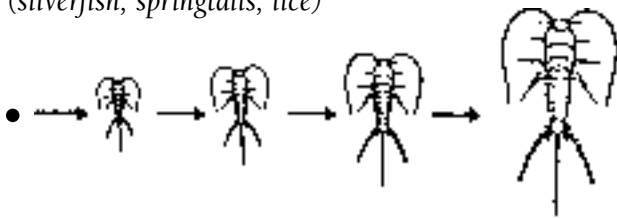

An insect in this category emerges from an egg looking exactly like a small form of the adult insect. It goes through several stages of shedding its skin, called **molting**, to grow larger until it reaches the full size of the adult.

## INCOMPLETE METAMORPHOSIS

(*grasshoppers, termites, true bugs, aphids, leafhoppers, earwigs, mayflies, dragonflies, stoneflies*)



An insect in this category hatches from an egg and becomes a **nymph** (the stage of an insect that does not have fully developed wings). The nymph goes through changes in its body as it molts (sheds its skin). One important change is that it develops wings. Once the insect molts and develops a full set of wings, it becomes an adult.

## COMPLETE METAMORPHOSIS

(*butterflies, moths, flies, bees, wasps, beetles, lacewings, caddisflies, fleas*)

An insect in this category has four different stages of growth. It hatches from an egg and turns into a larva, which looks like a worm or a caterpillar. Sometimes larvae have legs and sometimes they do not.

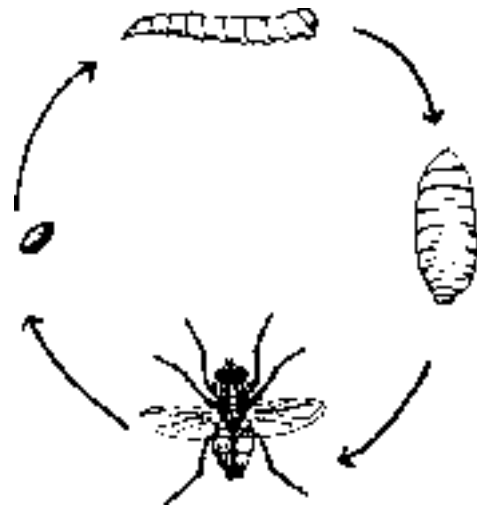

Once the larva has eaten enough food, it changes into a pupa. This is the quiet stage that does not move. Sometimes pupae have cocoons around themselves for protection. Cocoons can be spun from silk or can be a combination of leaves or debris. The pupa gradually changes form into the adult. The adult will break through the old skin of the pupa and the cocoon, if there is one, and begin its life as an adult.

# WINGS, MOUTHPARTS, AND METAMORPHOSIS REVIEW

Try to fill in the blanks without looking back at what you just read.

**1.** Can you describe three different kinds of insect wings? \_\_\_\_\_  
 \_\_\_\_\_  
 \_\_\_\_\_  
 \_\_\_\_\_

**2.** Can you name the different kinds of mouthparts insects have? \_\_\_\_\_  
 \_\_\_\_\_  
 \_\_\_\_\_  
 \_\_\_\_\_

**3.** After reading the sentences describing a type of metamorphosis, **circle the correct answer.**

**a.** The insect starts as an egg. A nymph hatches from the egg and sheds its skin many times. It develops wings and becomes an adult. What type of metamorphosis is this?

**simple                      incomplete                      complete**

**b.** The insect starts as an egg. It hatches into a larva. The larva eats a lot of food and changes into a pupa. The pupa remains quiet until the adult emerges. What type of metamorphosis is this?

**simple                      incomplete                      complete**

**c.** This insect starts as an egg. It looks just like the adult only smaller. It sheds its skin a few times and each time it gets bigger, but never changes its form. What type of metamorphosis is this?

**simple                      incomplete                      complete**

**4.** Match the terms on the left to the correct definitions on the right by writing the correct letter in the blank next to the terms.

\_\_\_\_\_ **membranous**

**A.** Clear wings with veins showing through

\_\_\_\_\_ **nymph**

**B.** Worm-like or caterpillar stage of an insect after it hatches from an egg

\_\_\_\_\_ **molting**

**C.** The process of changing form in the insect from egg to adult

\_\_\_\_\_ **pupa**

**D.** Tube-like mouthparts that take up food, as in butterflies and moths

\_\_\_\_\_ **metamorphosis**

**E.** The quiet stage of an insect before it becomes an adult

\_\_\_\_\_ **siphoning**

**F.** The process of shedding skin to grow bigger

\_\_\_\_\_ **larva**

**G.** The term for an insect stage without wings that hatched from an egg

## RELAXING DRY SPECIMENS

If you wait too long to pin an insect, its body parts may become hard and break. Or you may find an insect that is in pretty good condition, but has been dead for a while and may be stiff and hard to pin. To relax the body joints so that you can mount insects properly, construct a relaxing chamber.



**Relaxing Chamber**

### Materials you will need:

- jar or sealable container
- paper towels or napkins
- water source
- insects to relax

### Steps to prepare the chamber

1. Fold up the paper product so that it will fit in the bottom of the jar.
2. Moisten (do not soak) the paper with hot water so that moisture from the paper will seep into the insect's joints and loosen them.
3. Place the insect on the paper and close the lid of the jar tightly.

It usually takes about one to two days for most insects to relax. Check the specimens occasionally to keep the insect from becoming too wet or too soft. This is important because mold problems may develop if the chamber is too moist. Check to make sure the towel has not dried up. If so, remoisten it. You may put moth balls or naphthalene flakes in the chamber to inhibit mold growth.



## PINNING INSECTS

Insect pins are available from a supply company. Your leader will have these pins for you. Common straight pins should not be used because they will rust. Pins come in several sizes, but number 1 and number 2 pins are the most useful. For delicate soft insects like butterflies, flies, or bugs, use number 1 pins. For larger insects such as cicadas, and beetles, use number 2 or 3 pins. *If the pins are likely to crush or break the insect's wings or body when pinned, they should be put on a card point.* (See **How to Card Point Small Insects** on page 33.)

Insert the pin through part of the body from top to bottom.

The place of insertion depends upon the type of insect. The following rules apply when pinning different types of insects.

**1.** Bees, wasps, flies, etc.:

Pin through the **thorax** between bases of front wings and just to the right of the middle line.



**2.** True bugs: Pin through the **scutellum**, which is the triangular area between the bases of the wings.



**3.** Grasshoppers, crickets, etc.:

Pin through the **prothorax**.

This part looks like a saddle. Pin just to the right of the center line.



**4.** Beetles: Pin through the

**right front wing cover**

near the center line.



**5.** Butterflies, moths, dragonflies, etc.: Pin through the **center of the thorax** between the bases of top wings.

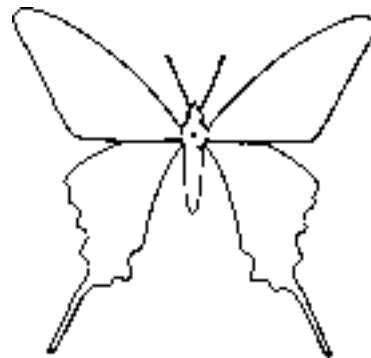

Three-eighths of an inch of the pin should project above the insect so that you can grasp the pin head with your fingers without damaging the insect. Use a pinning block to measure this distance.

# MAKING A PINNING BLOCK

A pinning block is used for setting the heights of the insects and labels on the insect pin so that all the insects and labels are the same height. You just learned where to pin certain types of insects. All you need to do next is make the pinning block and push the insect into the highest position.

Pinning blocks can be made by stacking rectangular pieces of wood or Styrofoam on top of each other and held together with glue, or by cutting corrugated cardboard to the prescribed heights. With the wood or Styrofoam, you need to make holes to fit pins into so they extend to the bottom.

You will push the pinned insect into the highest step of the pinning block. The insect should be about 3/8 inch from the top of the pin so that it can be easily transported using your fingers. The heights of each step are as shown.

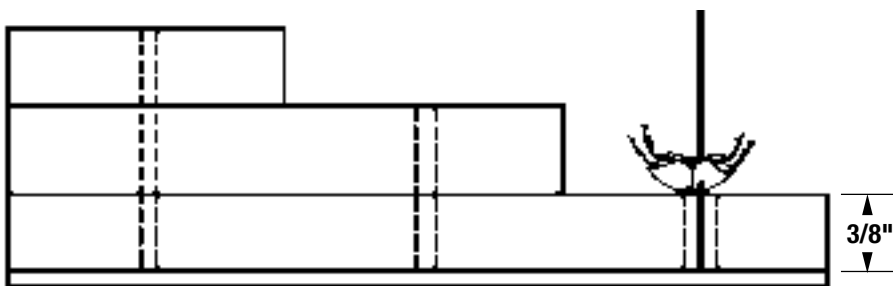
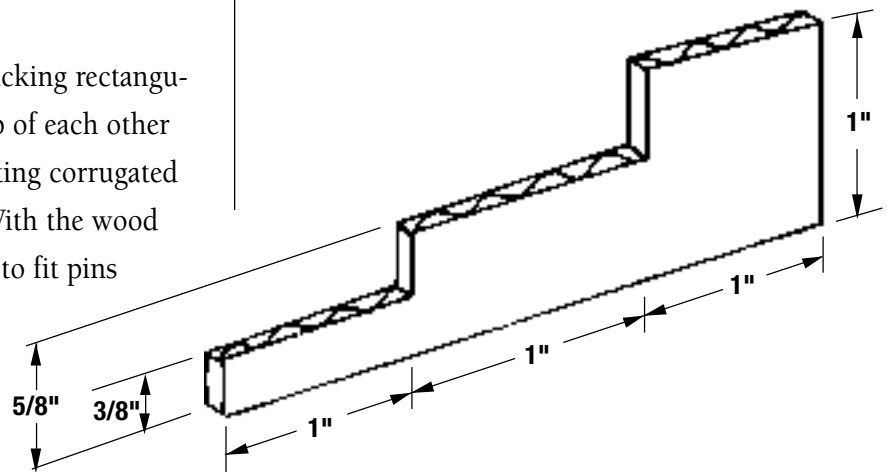

**Adjusting height of insect on pin**

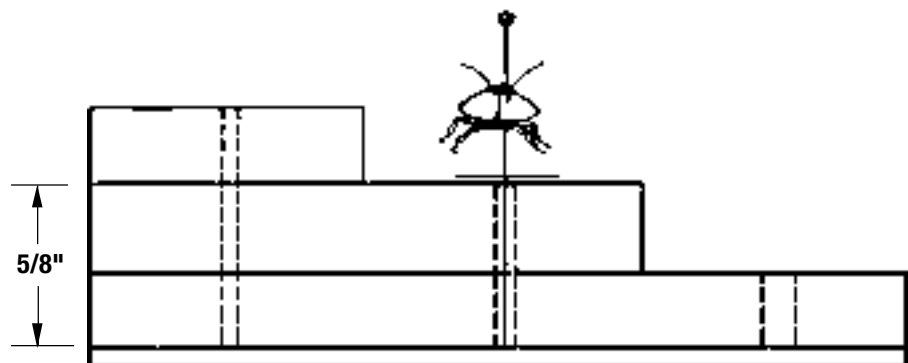

**Adjusting height of label**

# LEARNING THE MAJOR INSECT ORDERS

Let's look at some common orders of insects, the types of insects that fit into these orders, and some common characteristics of each order.

## COLEOPTERA (Coal lee op' ter uh)

The order Coleoptera includes **beetles** and is the largest



Long-horned Beetle

of all the insect orders. Beetles can be as small as the period at the end of this sentence. Some are as long as this page! You can find different types of beetles almost everywhere, and they eat almost anything. Beetles have **chewing mouthparts**. They have **two pairs of wings**.

of all the insect orders. Beetles can be as small as the period at the end of this sentence. Some are as long as this page! You can find different types of beetles almost everywhere, and they eat almost anything. Beetles have **chewing mouthparts**. They have **two pairs of wings**.



Ladybird beetle



Colorado potato beetle

*Coleo-* means “sheath” and *-ptera* means “wings,” referring to the fact that beetles have armored outer wings.

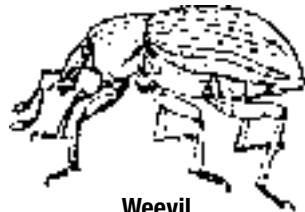

Weevil



Stag beetle

While the outer wings are hard or shell-like, the inner wings are membranous. Beetles undergo **complete metamorphosis**.

## DIPTERA (Dip' ter uh)

These insects include **flies** and **mosquitoes**. They have only **one pair of wings**, hence the name Diptera. *Di-* means “two,” and *-ptera* means “wings.” Flies also are a very large order of insects. Some flies have **sponge-like mouthparts** that help them lap up their food. They feed on plant or animal juices, nectar, sap, blood, or other insects. They can be found around decaying matter, food, or garbage. They secrete enzymes on the food to make it easier to take up. Other flies have piercing-sucking mouthparts and are able to “bite.” Mosquitoes have **piercing-sucking mouthparts** and are located near water sources, since they live in water as larvae. Dipterans have **complete metamorphosis**.



House fly

name Diptera. *Di-* means “two,” and *-ptera* means “wings.” Flies also are a very large order of insects. Some flies have **sponge-like mouthparts** that help them lap up their food. They feed on plant or animal juices, nectar, sap, blood, or other insects. They can be found around decaying matter, food, or garbage. They secrete enzymes on the food to make it easier to take up. Other flies have piercing-sucking mouthparts and are able to “bite.” Mosquitoes have **piercing-sucking mouthparts** and are located near water sources, since they live in water as larvae. Dipterans have **complete metamorphosis**.

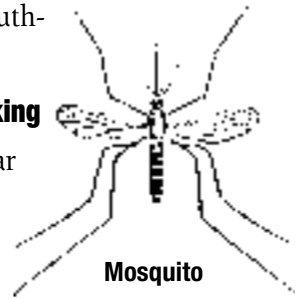

Mosquito

## MANTODEA (Man toe' dee uh)

This order includes **praying mantids** (or mantis). *Mantodea* means “soothsayer” referring to the way the insects holds their front legs in a praying position. There is no law against collecting mantids, as some people believe. Mantids are slow moving and fairly easy to collect. They feed on a variety of insects—even each other. They have **chewing mouthparts** and **two sets of wings**. They undergo **incomplete metamorphosis**.

This order includes **praying mantids** (or mantis). *Mantodea* means “soothsayer” referring to the way the insects holds their front legs in a praying position. There is no law against collecting mantids, as some people believe. Mantids are slow moving and fairly easy to collect. They feed on a variety of insects—even each other. They have **chewing mouthparts** and **two sets of wings**. They undergo **incomplete metamorphosis**.

There is no law against collecting mantids, as some people believe. Mantids are slow moving and fairly easy to collect. They feed on a variety of insects—even each other. They have **chewing mouthparts** and **two sets of wings**. They undergo **incomplete metamorphosis**.

They feed on a variety of insects—even each other. They have **chewing mouthparts** and **two sets of wings**. They undergo **incomplete metamorphosis**.

They undergo **incomplete metamorphosis**.

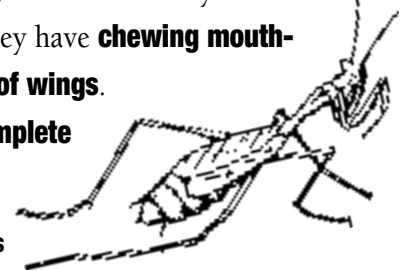

Praying mantis

**HYMENOPTERA** (High men op´ ter uh)

The order Hymenoptera includes **bees**, **wasps**, and **ants**. These insects are called Hymenoptera after

Hymeno, the god of marriage,

referring to the union of the front and the hind wings by a

row of tiny hooks. Some of these insects have **two pairs of wings**.



Velvet ant

The front wings are larger

than the hind wings. Most ants are wingless. Hymenopterans are found almost everywhere. Most of them have **chewing mouthparts**, but some

bees have **lapping mouthparts** that are

formed into a tongue-like structure that helps to take up liquids. These insects undergo **complete metamorphosis**.



Bumble bee



Thread-waisted wasp



Honey bee

**PHASMIDA** (Fas´ mi duh)

This order includes **walkingsticks**. As the name implies, these insects look just like sticks with legs. They are hard to confuse with other insects. They have **chewing mouthparts** and usually are in the tops of trees feeding on leaves. Occasionally one falls to the ground and is discovered making its way back to its favorite food source. They undergo

**incomplete metamorphosis**.



Walkingstick

**HEMIPTERA** (Hem ip´ ter uh)

Insects in the order Hemiptera are **true bugs**. *Hemi-* means “half” and refers to the fact that the wings of bugs are half thickened and half clear. The wings are folded in an X shape on the back when at rest.



Giant water bug

These insects have **two pairs of wings**.

They have a beak that houses their mouthparts, which are **piercing-sucking**.

This beak comes from the front part of the head.



Lace bug



Chinch bug

True bugs are found on land or in water and feed on plant juices, insects, or blood. They undergo **incomplete metamorphosis**.



Stink bug



Boxelder bug

**HOMOPTERA** (Home op´ter uh)

Insects in this order include **cicadas, hoppers, aphids, whiteflies** and **scale insects**. The last three insects listed have soft bodies and are small, so they won't

make good insects for your collection.

*Homo-* means "same" and refers to the fact that homopterans, unlike hemipterans, have front and hind wings with the same texture. Some homopterans have **one pair of wings,**

**some have two, and some have none.**

Like hemipterans, they also have a beak, except their beak comes from the back part of the head. They have **piercing-sucking mouthparts.**

All are plant feeders. Most are found on or around plants. Cicadas are found in trees in the summer. They make loud buzzing sounds. Homopterans undergo **simple metamorphosis.** Some aphids can lay eggs or give live birth!



**Treehopper**



**Cicada**



**Leafhopper**



**Aphid**

**ODONATA** (Owe da na´tuh)

The insects in this order include **dragonflies** and **damselflies**. *Odonata* means "tooth" and refers to the teeth on the mouthparts.

Odonata have **chewing mouthparts** and feed on insects or other small creatures.

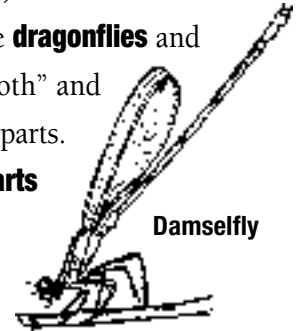

**Damselfly**

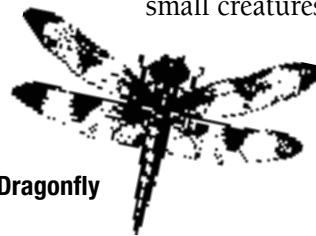

**Dragonfly**

They are usually found near the water. They have **two pairs of wings,** which are long and membranous.

These insects undergo **incomplete metamorphosis.**

**LEPIDOPTERA** (Lep i dop´ter uh)

The order Lepidoptera includes **butterflies** and **moths**. *Lepido-* means "scale," and *Lepidoptera* means "scale wings."

These insects have colored scales on their wings that rub off easily when handled. Try not to touch their wings when you collect these insects.

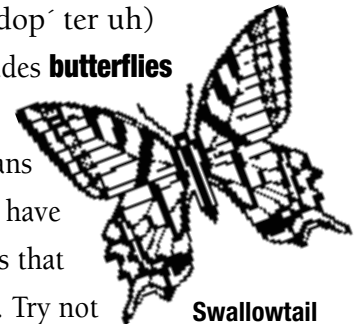

**Swallowtail butterfly**

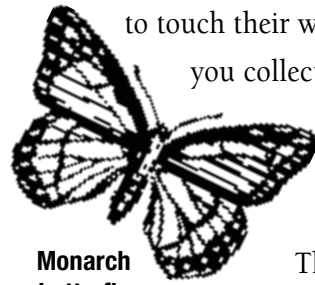

**Monarch butterfly**

There are 11,000 different kinds of Lepidoptera in the United States and Canada.

They are found almost anywhere and mostly

feed on nectar of flowers. They have a straw-like **siphoning mouthpart** called a **proboscis** to help them suck up nectar. Like beetles, they too undergo **complete metamorphosis.**

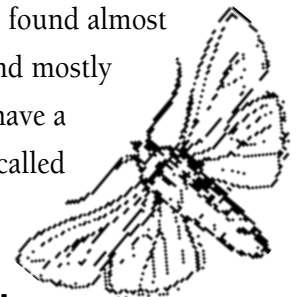

**Armyworm moth**



# MATCHING INSECTS TO THEIR ORDER

## ORTHOPTERA (Or thop´ ter uh)

The insects in this order include **grasshoppers, crickets, and katydids**. *Ortho-* means “straight,” referring to the **two pairs of straight wings** that these

insects have. Their front wings are thicker and are on top of the hind wings. They have **chewing mouthparts** and undergo **incomplete metamorphosis**.

Most of these insects can be found in grass or in fields of flowers.

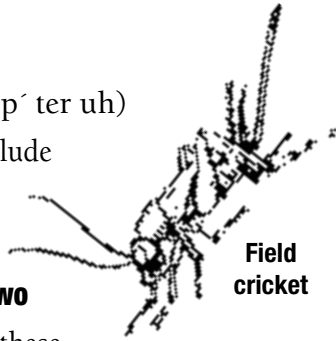

Field cricket



Grasshopper

## BLATTARIA (Blat tair´ ee uh)

This order includes **cockroaches**. They are general feeders with **chewing mouthparts**. Because they eat garbage and waste material, they have the reputation of being dirty insects. They are mainly nocturnal and are hard to catch because they move very fast. They can be found in the home, in leaf litter, and under bark. They have **two pairs of wings** and undergo **incomplete metamorphosis**.



Cockroach

Match each insect listed to the correct order. All of the blanks should be filled when you are done.

**BLATTARIA** \_\_\_\_

**COLEOPTERA** \_\_\_\_

**DIPTERA** \_\_\_\_, \_\_\_\_

**HEMIPTERA** \_\_\_\_, \_\_\_\_

**HOMOPTERA** \_\_\_\_, \_\_\_\_

**HYMENOPTERA** \_\_\_\_, \_\_\_\_, \_\_\_\_

**LEPIDOPTERA** \_\_\_\_, \_\_\_\_

**MANTODEA** \_\_\_\_

**ODONATA** \_\_\_\_, \_\_\_\_

**ORTHOPTERA** \_\_\_\_, \_\_\_\_

**PHASMIDA** \_\_\_\_

**A.** ant

**B.** butterfly

**C.** chinch bug

**D.** cicada

**E.** cockroach

**F.** cricket

**G.** damselfly

**H.** dragonfly

**I.** grasshopper

**J.** honey bee

**K.** house fly

**L.** lace bug

**M.** leafhopper

**N.** mosquito

**O.** moth

**P.** praying mantid

**Q.** stag beetle

**R.** walkingstick

**S.** wasp

## MAKING A SPREADING BOARD

In the past, spreading boards were made from a soft wood such as balsa, with a one-third inch groove running down the center. The insect's body lay in the center, and the rest of the insect was pinned around this groove. An easier method is to use a piece of flat Styrofoam from a broken cooler or purchased at a craft store. Any piece of material with a flat surface that will allow pins to go into it, like a cork board, will work for spreading insects. The material should be at least an inch thick.

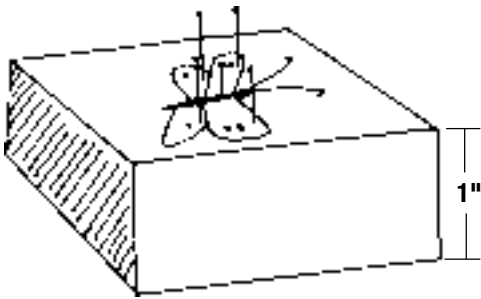

### How to mount insects

*Now that you have your spreading board, you can learn the proper way to spread insects. The point of spreading an insect is to make the insect look as real as possible. Your goal is to spread out the legs, wings, and antennae so that the insect looks natural. No one wants to see a collection of insects that look like they've been in a killing jar for fifteen years!*

Before you mount an insect, make sure you have pinned it in the correct spot on the body and located the insect at the right height on the pin using your pinning block. You should start with a specimen that looks like Figure A.

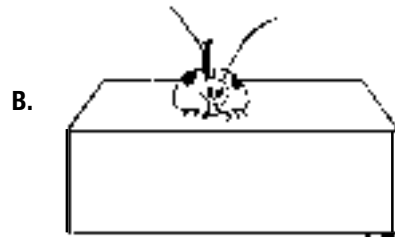
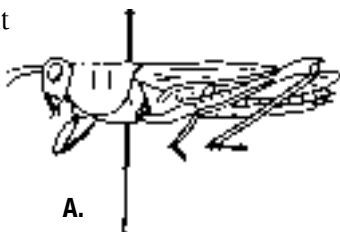

Except for butterflies and moths, insects should be pinned with their underside facing the Styrofoam. (See **HOW TO SPREAD BUTTERFLIES AND MOTHS.**) Push the pin into the Styrofoam just until the insect touches the surface (Fig. B).

Now you want to place pins in certain places to make the insect look as if it is crawling across the Styrofoam. You may have to use a lot of pins. **When arranging body parts, don't stick the pins in the insect!**

Use tweezers or a pin to hook the leg and bring it into position. Then hold the leg in place with a pin. You will probably have to insert the pin at an angle. Go over the leg and then stick the pin into the Styrofoam next to the leg. The pin should be lying over the leg, but not stuck in the leg (Fig. C).



Next you should pin the wings. Sometimes to get the wings to stay where you want them without bending or breaking them, you need to put a very small pin into the wings to hold them in place. Try to pick a spot on the wing that will not be very noticeable and make the hole only the size of the pin (Fig. D).

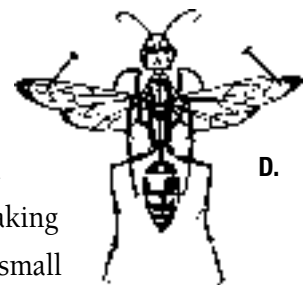

The last step is to pin the antennae in place (Fig. E).



## HOW TO SPREAD BUTTERFLIES AND MOTHS

It is easier to pin butterfly or moth wings when the insects are on their backs, because their body doesn't cause a bump, as it does when they are pinned face down. Since the scales might rub off onto the surface of the spreading board, put some wax paper over the board. Pull the paper tight so there are no wrinkles and tape it down. Using the sharp end of the pin, make a hole in the wax paper where you plan to spread the butterfly. Then invert

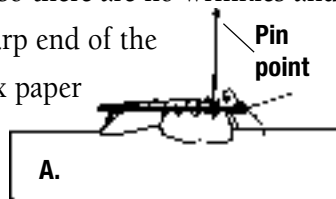

the pin so that the butterfly is upside down. Push the pinhead into the Styrofoam only to where the butterfly touches the board. Because the pin will be sticking straight up, be careful not to prick yourself when working. See Figure A.

With butterflies and moths, we really don't need to worry about the legs because they are thin and hidden by the wings.

To properly mount the wings, insert an insect pin lightly (try to use a number 0 or 1 pin) in each forewing. Slowly move the front wings away from you until the bottom of the front wings are horizontal. See Figure B. Stick the pin gently into the foam when you are satisfied. If you need to move the wings again, simply lift the pin, move the wings, and replace the pin.

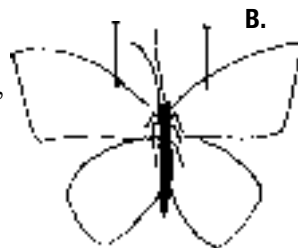

Next move each hind wing up until the gap between the front wing and hind wing is closed to just a notch, as shown on the right side of Figure C. Once you have obtained the proper position, gently stick the pin into the foam.

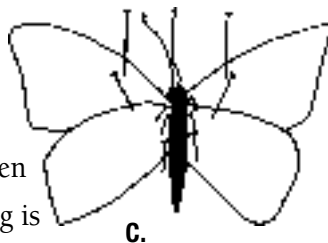

You can let the insect dry in this position after you fix the antennae. Depending on the amount of moisture in the air, the specimen should remain on the board for two to four days.

If you are more ambitious, you can avoid the hole marks in the wings. Insert the butterfly or moth in the foam, as in Figure A. Cut some narrow strips of paper and place them firmly over the wings. Pin them in place as shown in Figure D.

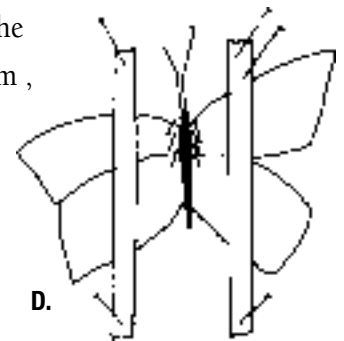

The pins holding the paper strips in place should not go through the wings but should be close enough to them to keep enough pressure on the wings to prevent them from slipping out of place. Without poking a hole through the wing, use a pin or tweezers to move the right forewing into place. With a pin, lightly touch the wing and drag it into position. Once the wing is where you want it, put a pin in the paper strip closer to the wing to hold it in place. See Figure E.

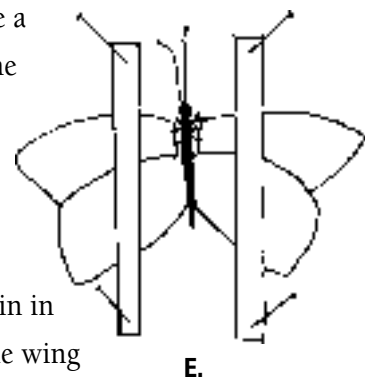

Repeat this step for each of the remaining three wings.

Don't forget to pin the antennae in place. Some entomologists use transparent paper like wax paper so they can see if the wings have slipped out of place while the specimen is drying. However, if the paper is too thin, there will not be enough pressure on the wings to keep them in place.

## FIELD TRIP

So far, we have talked about what insects are, how they live, and where they live. Now, let's put our knowledge to work! Taking a field trip will give you the opportunity to put everything you have learned so far into practice. You may have learned how to catch a paper insect in your net, but how good are you at catching a real butterfly, grasshopper or dragonfly?

There are several collection laws that you will need to follow. In Pennsylvania, you are **NOT** allowed to collect at state or national parks without permits. You **CANNOT** transport live insects over state or international lines. You can only collect aquatic insects if you are over 16 and have a fishing license; you also need an educational aquatic field study permit from the Pennsylvania Fish and Boat Commission. Once you obtain these permits, you may only collect a **MAXIMUM** of 50 aquatic insects. Some states **DO NOT** allow you to collect at all. Please check with the proper authorities before you take your trip.

**Before you attend the field trip**, you should look through your guides or go to a library and look up some insects you would like to have in your collection. Study their preferred habitats and the type of food they eat, so that you will know where to find them.

**On the field trip**, catch anything that you think is interesting and would like to have in your collection. If you don't know what the insect is at the time of collection, you can look it up later, but don't forget to make notes in your record book about the insect! Remember, this information is important for identifying the insect as well as labeling it for your final collection.

### What to bring

On this field trip, you will need to bring all of your collecting equipment including:

- **collecting net**
- **killing jar**
- **insect holding container**  
(to hold the insects until they are mounted)
- **insect field guides**
- **4-H guide with record pages**

*You will not need your spreading board or pinning block, since you do not pin insects at the collecting site.*

## Don't overcrowd your killing jar with insects!

The field trip is not an insect shopping spree where you collect as many insects as possible. If you do this, you will be sorry. If ten bugs are crowded into the killing jar, only one or two will come out nice enough to include in your collection. Take your time and have fun. Show your leadership and maturity on this field trip and be a positive role model for those younger than yourself.

## After the field trip

Take your insects that are in the holding container and try to pin as many as you can while they are still fresh and flexible. You may need to use the relaxing chamber for those that have stiff joints.



*Happy Hunting!*

# ACTIVITY: LESS COMMON INSECTS

Meeting 4 introduced the ten most common insect orders for general collections. This meeting presents the minor insect orders.

## DERMAPTERA (Der map' ter uh): **earwigs**

These insects have one or two pairs of membranous wings or no wings.

Mouthparts are chewing, and

metamorphosis is incomplete. Der-

maptera are found in damp or dark areas of homes. They have distinct pinchers at the tip of their abdomens. It was once believed these insects crawled into people's ears while they were asleep!

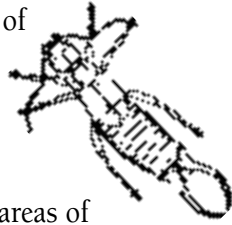

## EPHEMEROPTERA (E fem er op' ter uh): **mayflies**

These insects have two pairs of membranous wings.

The first pair is much larger than the second. Metamorphosis is incomplete. Ephemeroptera spend all but one or two days of their lives in the water.



They emerge as adults, fly out of the water, shed their skin,

mate, lay eggs, and die all within a day or so. They have no mouthparts as adults because they don't live long enough to need food.

## ISOPTERA (Eye sop' ter uh): **termites**

Worker termites are wingless; others have two pairs of membranous, same-length wings. Their mouthparts are chewing, and metamorphosis is incomplete. These insects resemble



Winged adult

ants and live in colonies. You can find them around decaying wood, which is their main food.



Soldier



Worker

## NEUROPTERA (Nur op' ter uh): **dobsonflies, lacewings, antlions**

These insects have two pairs of membranous wings. Their mouthparts are chewing, and metamorphosis is complete. The name *neuroptera* means "nerve wings" and



Dobsonfly

refers to the many veins in the wings. Some larvae in this order are found in the water.

Lacewings are probably the most common insect found in this order.



Lacewing

## PLECOPTERA (Plee cop' ter uh): **stoneflies**

These insects have two pairs of membranous wings. Their mouthparts are chewing, and metamorphosis is incomplete. They are usually found near streams. Adults can be found resting on bridges or fence posts near water sources.



## THYSANURA (Thy san your' uh): **silverfish**

These insects have no wings. Their mouthparts are chewing, and metamorphosis is simple. They are likely to be found in the bathroom or running along a bookshelf. For food they tend to like starchy products, such as wallpaper or book glue. They run fairly quickly and are hard to catch. If squished, their insides are very powdery because of their diet.



## TRICHOPTERA (Tri cop' ter uh): **caddisflies**

These insects have two pairs of wings. Their mouthparts are chewing, and metamorphosis is complete. The larvae of caddisflies are found in ponds, lakes, or streams. Some types of larvae make cases of twigs, leaves, and silk around



their bodies. The adults look like moths. Insects in the following orders are so small that it is unlikely that you will catch them and be able to display them properly.

**COLLEMBOLA** (Coal lem´ bowl uh): **springtails**

These insects have no wings. Their mouthparts are chewing, and metamorphosis is simple. Springtails are common, but are rarely seen because of their small size and their hidden habitats. Most springtails live in soil, leaf litter or bark. They get their name from the fact that they can jump very high when disturbed.



**ANOPLURA** (Ann oh pler´ uh): **sucking lice**

These insects have no wings. Their mouthparts are piercing-sucking or chewing, and metamorphosis is simple. Lice are not very pleasant because they are usually found on us or on animals. Their feeding can make a person or animal very uncomfortable.



Some lice carry diseases. They are very small and can travel on the strands of hair.

**SIPHONAPTERA** (Sigh fun apt´ ter uh): **fleas**

These insects have no wings. Their mouthparts are piercing-sucking, and metamorphosis is complete. Fleas are usually found on household dogs and cats. They can get into the carpet and bother humans as well. They feed off the blood of animals. They can jump very high. Like lice, fleas can carry diseases



## Activity: The Less Common Insects

- Which insect builds a house or case around its body?
  - stonefly
  - caddisfly
  - earwig
- Which insect has no mouthparts as an adult because it only lives as an adult for a day or two?
  - silverfish
  - termite
  - mayfly
- Which insect was once thought to crawl into a part of your body while you were sleeping?
  - earwig
  - termite
  - flea
- Which insect might you find in your bathroom?
  - springtail
  - silverfish
  - caddisfly
- Which insect might be found on your dog or cat?
  - earwig
  - springtail
  - flea

## USING A KEY

A key can help you figure out what order your insect is in. Some insect keys can be very specific and lead you to a particular species of insect. By looking at certain characteristics and referring to the branches of the key, you will eventually narrow down the insect to one order. To make the key easier to use, a few rarely encountered insect orders are not included. As a result, some insects will not be accurately identified by this key. The use of additional insect guides may help you identify your insects.

The best way to understand how a key works is to dive right in and get started. Here is an exercise that will take you step by step through the key to figure out how to identify the order of insect.

Look at the insect tree key in your guide. The exercise below provides a list of characteristics of an insect. When the key comes to a fork with several options, choose the one that best describes your insect.

For example, you need to ask yourself, does my insect have wings or not? If yes, you need to go to the top of the key where it says “wings.” Then the key asks you if your insect has one pair or two. If your insect has two, then ask yourself if your insect has scales, a shell-like covering on its wings or clear membranous wings, and so on.

### Example:

This insect has: **wings**  
**two pairs**  
**scales**

Answer: **Lepidoptera**

1. This insect has: **no wings**  
**doesn't jump**  
**thick waist**  
**found on animals**

Answer: \_\_\_\_\_

2. This insect has: **no wings**  
**doesn't jump**  
**thick waist**



*In this situation, since the outcome could be one of three orders, you need to look at the insect shown on the key and compare it to the one you have.*

Answer: \_\_\_\_\_

3. By looking at this picture, see if you can take this insect through the key with the help of two characteristics that you cannot see in the picture:



**found around water**  
**chewing mouthparts**

Answer: \_\_\_\_\_

4. This insect has: **two pairs of wings**  
**clear, membranous wings**  
**chewing mouthparts**  
**pinchers at the end of the abdomen**

Answer: \_\_\_\_\_



**PICTURE KEY TO ADULT INSECTS WITH WINGS**

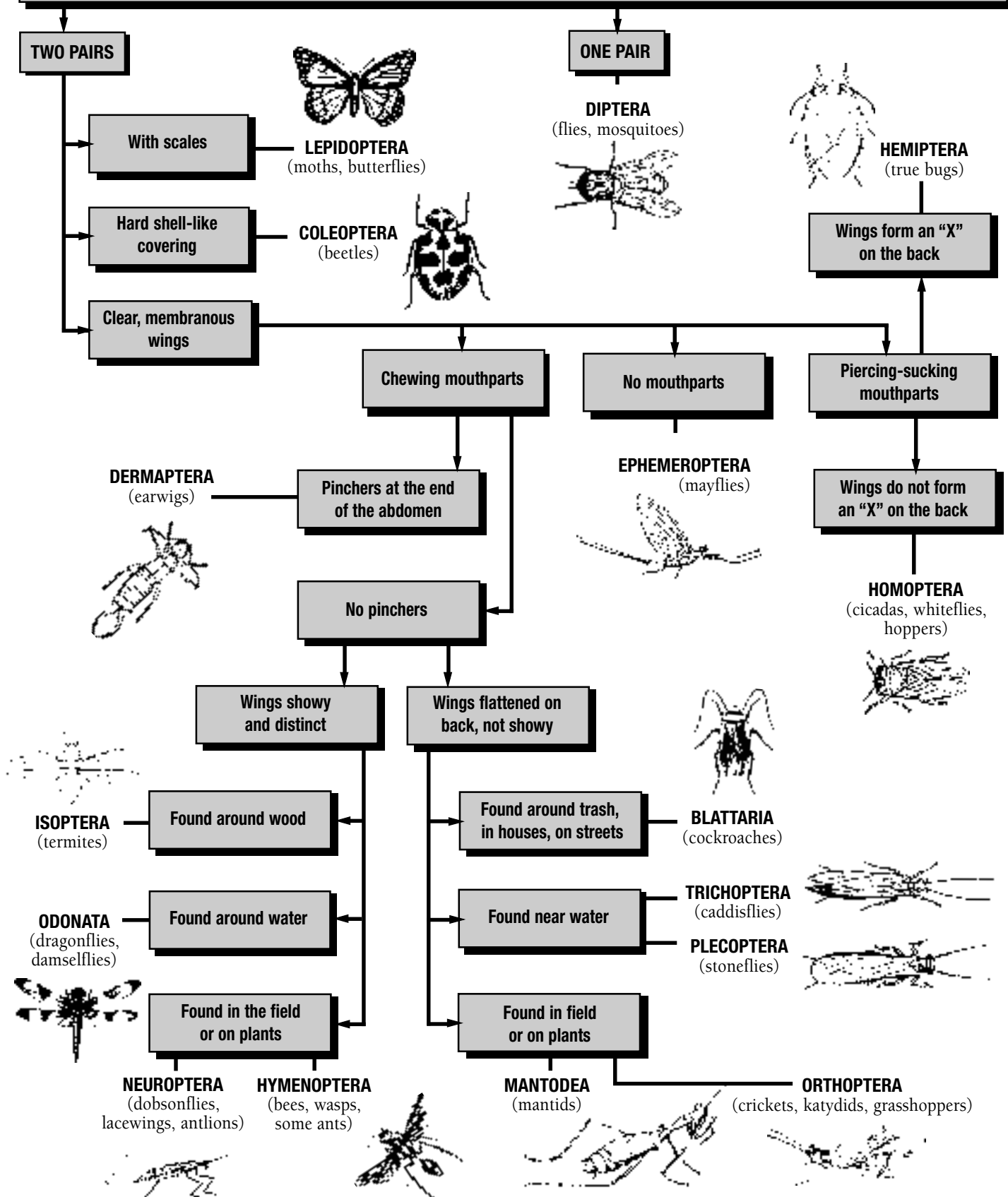

PICTURE KEY TO ADULT INSECTS WITHOUT WINGS

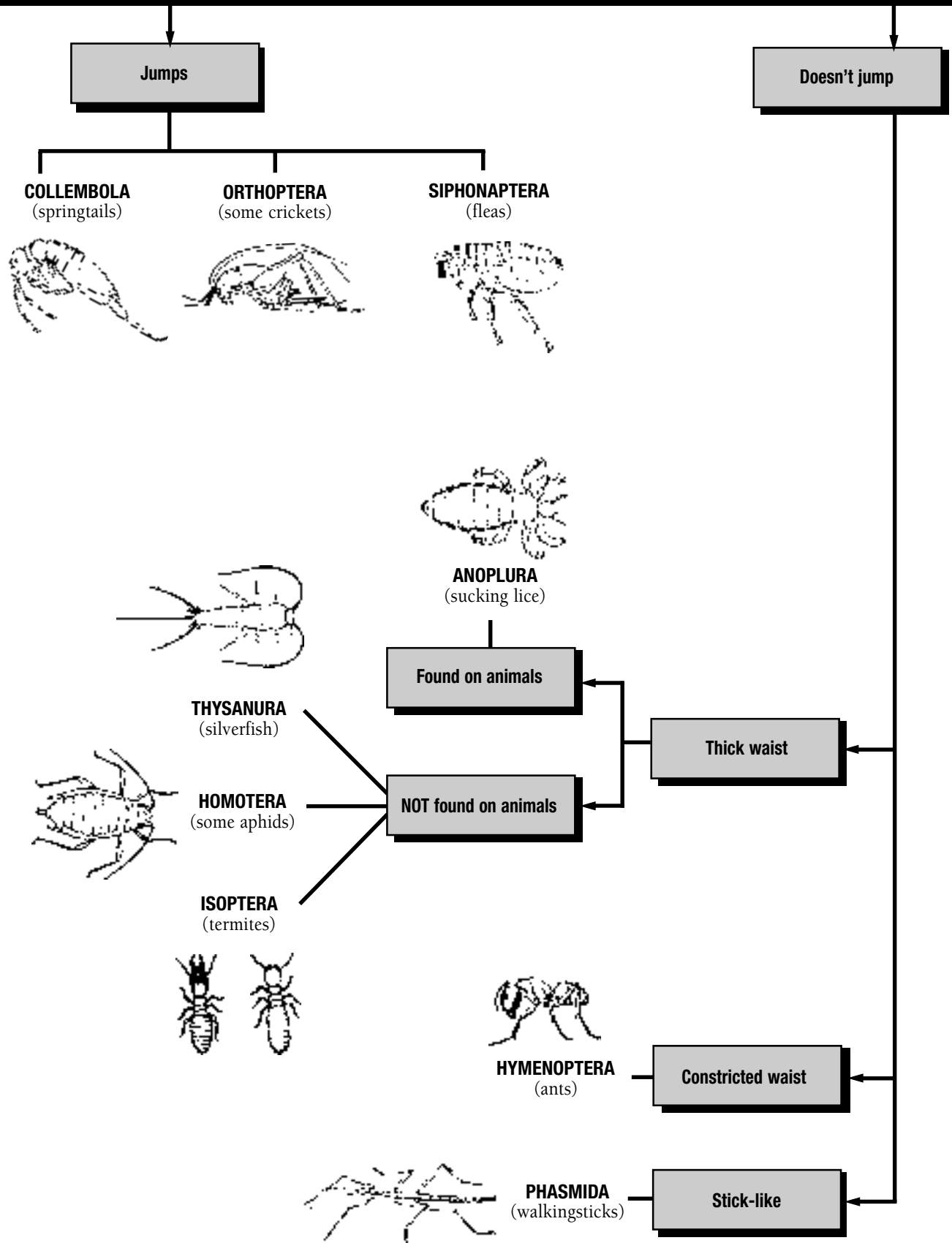

# CARD POINTING AND LABELING INSECTS

## How to card point small insects

To mount insects that may be too small to fit on a pin, you can use card points.

1. Select some heavy paper, such as filing cards, for cutting out card points.
2. Cut the points in the shape shown. The points should be about 3/8 inch long.

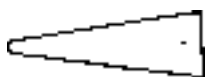

3. Put a pin (usually a number 1 or 2) through the base of the card point and push it up to about 1/4 inch from the top of the pin. Use a pinning block to get uniform heights of the points.

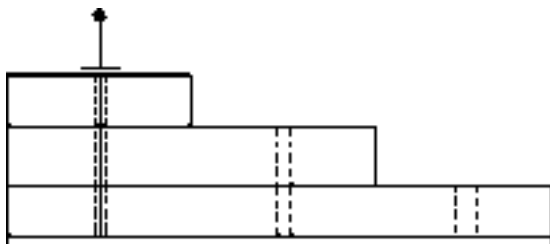

4. With a pair of tweezers, bend the tip of the card point down, as shown in the sketch below.
5. Put a tiny drop of glue or clear fingernail polish on the bent-down part of the card point and press it gently to the underneath right side of the insect. Be sure the insect is horizontal and not at an angle. This takes practice.

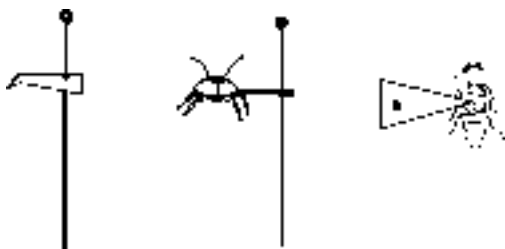

## Labeling insects

Labels should be printed on heavy paper, such as note-cards. The most important label is the one that tells where, when, and by whom the insect was collected. This label is called the “locality label” and is placed right under the insect on the insect pin. Put the pin directly through the center of the label and push it down to the second step level of your pinning block. Every pinned insect should have this label. The other label is the “identification” label. This label includes the common and/or scientific name of the insect, or the insect order. The “identification” label is also placed on the pin directly through the center of the label. Push it down to the lowest step on your pinning block.

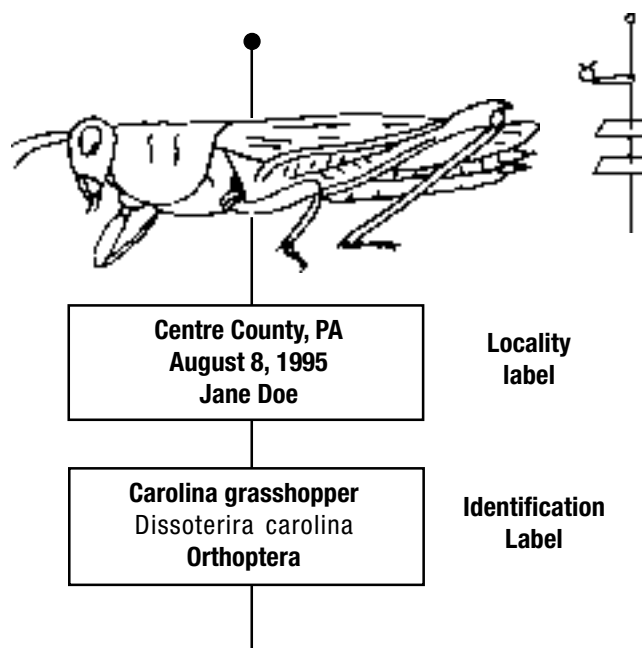

# THE SCIENTIFIC NAME

Insect orders are further separated into families, then genus, then species. Sometimes they are even divided into suborders, subfamilies, and subclasses! Then things start to get crazy. Let's look, for example, at the classes of the common honey bee.

**Kingdom :** Animal

**Phylum :** Arthropoda

**Class :** Hexapoda

**Order :** Hymenoptera

**Family :** Apidae

**Genus :** Apis

**Species :** mellifera

You know this part already!

Don't panic. These words probably all look foreign to you, and they should because they are Latin words. You don't have to know what they mean, but you will need to label some of the insects in your collection by order or scientific name.

An insect is called by its scientific name, which is made up of the **genus** and the **species**. The genus name always starts with a capital letter, and the species name is always lowercase. Now you know how to form a scientific name. By using the information provided, what is the scientific name of the honey bee?

**Write your answer here:**

---

Did you guess *Apis mellifera*? As an entomologist, you must remember that all scientific names should always be either italicized or underlined (if you can't make italic letters).

## The Name Game

Here's an exercise to help you with naming. What's wrong with each of the names? Make your corrections in the space provided. If the names are correct the way they are given, leave the space blank. There may be more than one thing wrong with some names.

*Hint: Since you can't write in italics, make sure all your names are underlined. Also, see if the first letter of the genus name is capitalized and the first letter of the species name is lowercase.*

Example: **musca domestica** (house fly)

Musca domestica

**1. Danaus plexippus** (monarch butterfly)

**2. Periplaneta Americana** (American cockroach)

**3. Schistocerca americana** (American grasshopper)

**4. drosophila Melanogaster** (fruit fly)

**5. Solenopsis Geminata** (fire ant)

## FIND THE IMPOSTORS

There is another important fact about naming insects that you, as a future entomologist, should know. Not all bugs and flies are classified as true bugs or real flies. For example, a house fly is a real fly. It is classified in the order Diptera, or true flies. But a firefly isn't a real fly. It is in the same order as beetles. Did you notice any difference in the way the two names are formed? Look at the words house fly and firefly again. What do you notice?

Did you notice that house fly has a space between house and fly, but firefly is one word? In most cases, you can identify the impostor because this name is all one word.

Here is another exercise for you to practice. See if you know which insects are real and which are impostors. You may have to look up these insects in a guide (check the index in the back) to learn what order they are in, or check your 4-H guide and write down what order the insect is in. You will then know which insect is in the true fly (Diptera) or true bug (Hemiptera) order and thereby tell the impostor. Look at the first example for help.

Ex. **housefly**

*Diptera*

**butterfly**

*Lepidoptera*

**Circle the one that is a true fly. How should it be spelled?**

*house fly*

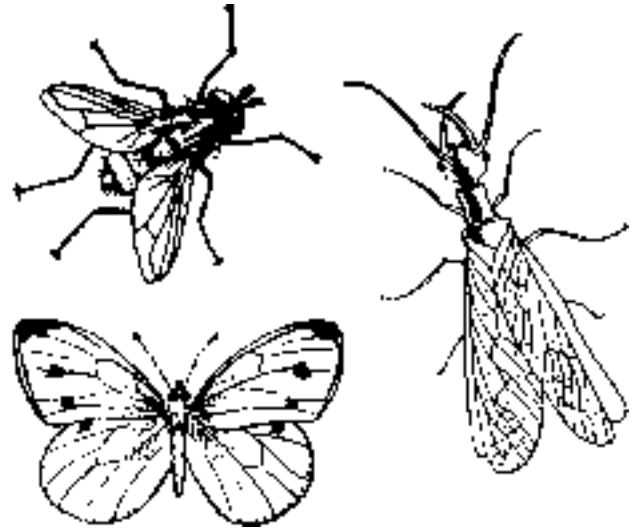

**1. bottlefly**

**dobsonfly**

**Circle the one that is a true fly. How should it be spelled?**

**2. giant waterbug**

**spittlebug**

**Circle the one that is a true bug. How should it be spelled?**

# FIND THE IMPOSTORS

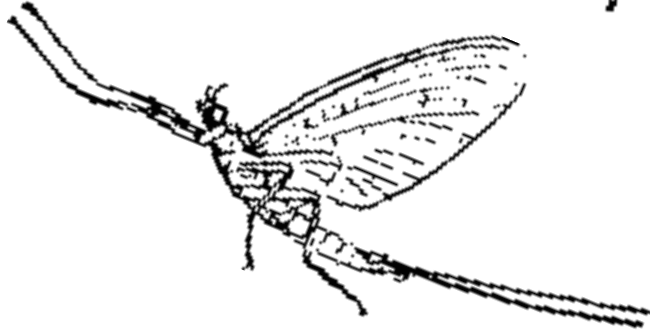

3. cranefly

\_\_\_\_\_

caddisfly

\_\_\_\_\_

Circle the one that is a true fly. How should it be spelled?

\_\_\_\_\_

5. mayfly

\_\_\_\_\_

horsefly

\_\_\_\_\_

Circle the one that is a true fly. How should it be spelled?

\_\_\_\_\_

4. lightningbug

\_\_\_\_\_

bedbug

\_\_\_\_\_

Circle the one that is a true bug. How should it be spelled?

\_\_\_\_\_

6. dragonfly

\_\_\_\_\_

fruitfly

\_\_\_\_\_

Circle the one that is a true fly. How should it be spelled?

\_\_\_\_\_

## HOW TO MAKE A COLLECTION BOX

### Materials:

- cardboard box or similar sturdy box with a lid
- piece of corrugated cardboard, soft fiberboard, or Styrofoam
- glue
- mothballs to keep pests out of collections
- match box to hold moth crystals

### Procedure:

1. Cut the cardboard to fit the bottom of the box.
2. Smear glue on the bottom of the box and insert the cardboard.
3. Line the box with white paper.
4. Fill the match box with moth crystals.
5. Pin the match box in a corner of the collection box.

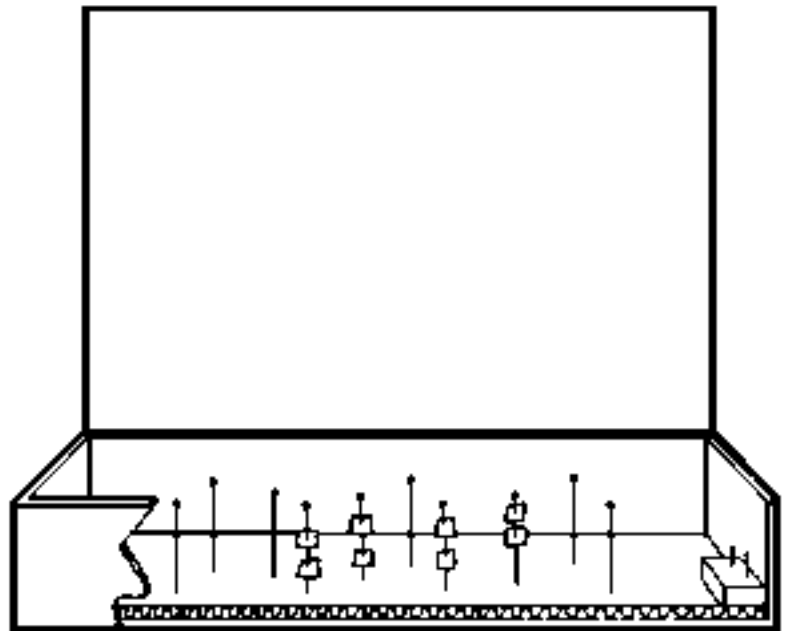
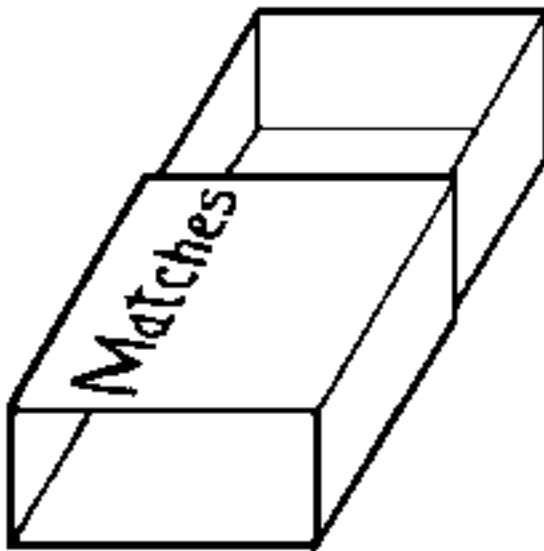

# HOW TO MAKE A DISPLAY CASE

## Materials:

- piece of masonite or hardboard for bottom: **18 by 24 inches**
- two pieces of pine for sides: **3/4 by 3 1/2 by 24 inches**
- one piece of pine for the end: **3/4 by 3 1/2 by 16 1/2 inches**
- one piece of pine for the end: **3/4 by 3 1/8 by 16 1/2 inches**
- One piece of foam core or similar soft fiberboard for pinning floor: **16 1/2 by 22 1/2 inches**
- One piece of window glass: **1/8 inch thick; 17 by 23 1/2 inches**

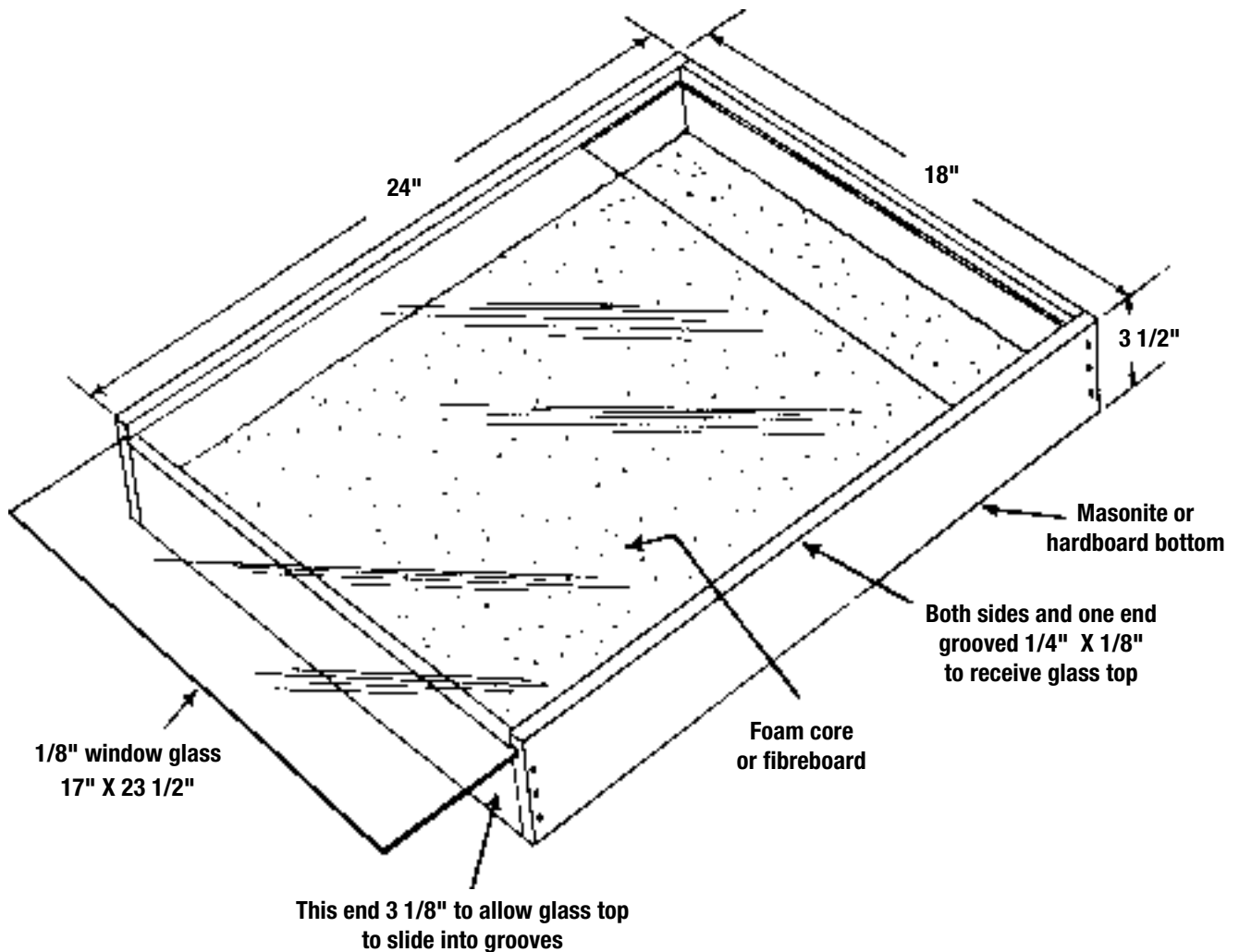



## PRESENTATIONS AND COLLECTIONS ON DISPLAY

By now you all have a collection to display and a presentation to give. You have made it through collecting and identifying insects. Congratulations! Here are some extra activities that you can do now that you have completed this guide.

### Making your own traps

If you would like to make your own traps for collecting insects, here are a few suggestions:

**A.** Put out a plate containing a mixture of sugar and water. On a nice day, you should attract many insects, such as butterflies, ants, flies, and bees. Be careful when catching bees or yellow jackets because they can sting you.



**B.** Another way to attract butterflies is to take specimens that you have already caught and killed and place them in a pile of flowers, as if they were still alive. Other butterflies will come over to see why the specimens are there. You can then collect the butterflies you have attracted.

**C.** One way to catch ants and other scavengers is by giving them a picnic. Put out crumbs from your lunch somewhere your mom or dad won't mind having ants. Within about a half hour, you should see ants on the food.

**D.** Nighttime is a great time to catch some insects that people rarely see. You can attract several moths at night by hanging a white sheet over a tree limb. If you put a light in front of the sheet, moths and other night-flying insects will be attracted to the light and hit the sheet. Then you can catch them.

**E.** You can also catch insects that crawl on the ground. Dig a hole in the ground big enough to hold a jar or plastic cup. Place a funnel in the top of the container and secure it. Pour some alcohol in the container. Cover the container with leaves so that insects will fall into the container and not be able to escape. Check the container in a couple of days.

**F.** If you want to see the different stages of a fly, put a piece of meat in a jar and let it stand outside on a warm day for about an hour. Cover the top of the jar with a material that allows air to pass in and out. In about a day, you will notice small maggots crawling in and out of the meat. In a week or so, they will change into pupae. After being still for a week or two, they will hatch into flies.

## **ENTOMOLOGY SOCIETIES THAT YOU MAY JOIN**

---

### **Entomological Society of Pennsylvania (ESP)**

c/o Department of Entomology

The Pennsylvania State University

501 ASI Building

University Park, PA 16802

(814) 865-1895

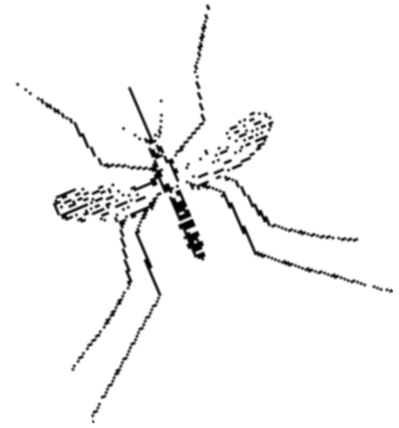

### **Young Entomologists' Society, Inc. (YES)**

International Headquarters

1915 Peggy Place

Lansing, MI 48910-2553

(517) 887-0499



### **Entomological Society of America (ESA)**

9301 Annapolis Road

Lanham, MD 20706-3115

(301) 731-4535

For older members in high school or college,  
or for parents and leaders



















**abdomen** (ab´ doe min): the part of an insect's body behind the thorax that contains the organs of digestion and reproduction.

**antennae** (an ten´ ay): the rod or feather-shaped projections on the front of the head that serve as organs of touch and sometimes taste, smell, and hearing. They are often called "feelers."

**Arachnid** (A rack´ nid): spiders and their relatives.

**Arthropods** (Arth´ ro pods): the phyla that insects are in, meaning "jointed legs."

**Chilopoda** (Chill a pode´ a): centipedes.

**chitin** (kite´ in): the material that is found in the exoskeleton of insects.

**complete metamorphosis** (met a more´ foe sis): four different stages of growth, including egg, larva, pupa, and adult, as found in butterflies, moths, flies, bees, wasps, and beetles.

**Diplopoda** (Dip low pode´ uh): millipedes.

**exoskeleton** (x o skell´ it tin): a skeleton (hard covering) on the outside of the body which gives an insect protection.

**Hexapoda** (Hex a pode´ a): insects.

**incomplete metamorphosis** (met a more´ foe sis): a process of change in which insects such as grasshoppers, termites, true bugs, aphids, leafhoppers, and earwigs hatch from an egg, become a nymph, molt, and develop a full set of wings, thereby becoming an adult.

**invertebrates** (in vert´ i brates): animals without a backbone.

**key:** a set of characteristics organized in branches to help the user narrow down choices and identify a particular insect.

**larva** (lar´ vuh): the immature stage that occurs after insects that undergo complete metamorphosis hatch from the egg; larvae sometimes resemble caterpillars or worms.

**membranous wings** (mem bran´ us): clear wings with veins showing through, as on a dragonfly.

**metamorphosis** (met a more´ foe sis): a process in which insects grow up and change their form.

**molting** (molt´ ting): the process by which an insect sheds its skin to grow larger until it is the full size of the adult.

**nymph** (nimff): the immature stage of an insect that does not have wings.

**proboscis** (pro bos´ sis): a siphoning mouthpart in butterflies and moths that is like a straw to help suck up nectar.

**prothorax** (pro thor´ axe): part of the neck area that is used for pinning some insects.

**pupa** (pew´ puh): the stage of complete metamorphosis between the larva and the adult.

**scales:** tiny, shingle-like parts of butterfly and moth wings that rub off like powder.

**scientific name:** a Latin name for insects that is made up of the genus and species.

**scutellum** (skew tell´ um): the triangular area between the bases of the wings on some insects.

**simple metamorphosis** (met a more´ foe sis): the process of metamorphosis in which insects such as silverfish, springtails, and lice hatch from an egg and look exactly like a small form of the adult insect.

**siphon** (si´ fun): tube-like mouthpart that takes up food.

**thorax** (thor´ axe): the middle part of an insect where the legs and wings are attached.

# 4-H ACTIVITIES REPORT

This report will help you keep a better record of your club activities. Fill it in as you complete each assignment. Refer to this record when you are entering county, state, and national programs. Ask your local leader to explain these programs to you.

My 4-H Activities Report for the 19 \_\_\_\_\_ Club Year

Projects taken \_\_\_\_\_

\_\_\_\_\_

\_\_\_\_\_

\_\_\_\_\_

Offices held \_\_\_\_\_

\_\_\_\_\_

Club \_\_\_\_\_

County \_\_\_\_\_

“Show-and-tells” given to

Family \_\_\_\_\_

Friends \_\_\_\_\_

Local club \_\_\_\_\_

County \_\_\_\_\_

Regional \_\_\_\_\_

State \_\_\_\_\_

News articles \_\_\_\_\_

Radio \_\_\_\_\_

TV \_\_\_\_\_

Things done to improve my health \_\_\_\_\_

\_\_\_\_\_

\_\_\_\_\_

Community service or citizenship work done

By myself \_\_\_\_\_

With club \_\_\_\_\_

Number of meetings my club(s) held this year \_\_\_\_\_

Number I attended \_\_\_\_\_

Number of new members I encouraged to join 4-H \_\_\_\_\_

Number of boys and girls I helped with projects \_\_\_\_\_

In what way? \_\_\_\_\_

\_\_\_\_\_

\_\_\_\_\_

Check those attended and tell how you helped

\_\_\_\_\_ 3- or 4-day camp

\_\_\_\_\_ 1-day camp

\_\_\_\_\_ Club or county tours

\_\_\_\_\_ Club picnic

\_\_\_\_\_ Countywide picnic

\_\_\_\_\_ 4-H Sunday

\_\_\_\_\_ County fair

\_\_\_\_\_ Achievement programs

\_\_\_\_\_ Roundup

\_\_\_\_\_ Teen Leader Retreat

\_\_\_\_\_ State 4-H Capital Days

\_\_\_\_\_ Camp Leadership Training

\_\_\_\_\_ Penn State 4-H Achievement Days

\_\_\_\_\_ Pennsylvania Farm Show

\_\_\_\_\_ National 4-H Week

\_\_\_\_\_ State Ambassador Conference

\_\_\_\_\_ Judging training

Others:

\_\_\_\_\_

\_\_\_\_\_

\_\_\_\_\_

## **4-H Club Motto**

“To make the best better”

## **4-H Club Pledge**

I pledge  
my head to clearer thinking,  
my heart to greater loyalty,  
my hands to larger service, and  
my health to better living, for  
my club,  
my community,  
my country, and  
my world.

## **4-H Club Colors**

Green and White

Name \_\_\_\_\_

Address \_\_\_\_\_

\_\_\_\_\_

Name of club \_\_\_\_\_

Leader's name \_\_\_\_\_

